





# Masters of the Italian bicycle from 1964.

Guerciotti is a pillar of Milanese style, an icon of success in cyclocross, a brand that looks at the future while maintaining solid family management. Alessandro and Micaela Guerciotti have taken up the challenge launched by their father Paolo, building bicycles designed to excite the next generation of cyclists. 60 years after its foundation, Guerciotti bikes are still the brightest stars in Milan.

# Content index

Corporate	
A family tradition since 1964	06
News	
Our Sixty	22
Inspired by Milano	26
Madame Project	30
Milano: our first Urban e-bike	34
E-Bikes	
Polini E-P3 + GP	46
Navir I.ON	48
Sempione I.ON	54
Brera I.ON	57
Greto I.ON 630	62
Greto I.ON	66
IDT5 System	70
Ambrosia	72
Gaia	76
Road bikes	
QTC carbon integrated handlebar	80
Eclipse S 2025	81
Veloce SLR	92
Veloce S	96
Italo	100
Cartesio Disc	104
Cartesio Rim	108
San Siro	112
Gravel bikes	
Escape	116
Brera	122
Greto S	126
Greto	130
Cyclocross bikes	
Guerciotti: cross soul	136
Eureka CXS	138
Silvelle	142
Tech specifications	
Geometrie	146-166

# A family tradition since 1964

Sixty years have passed since the historic Guerciotti bicycle brand took its first steps within the walls of the first shop in via Petrella in Milan, back in 1964. Sixty years of commitment, dedication and passion, which have given life to highly prestigious bicycles that have been pedaled by numerous champions from cycling's past, such as Giovan Battista Baronchelli, and from more recent history, including Gilberto Simoni, Alessandro Bertolini, and then Michele Scarponi and Davide Rebellin.

To best celebrate its first 60 years of activity, Guerciotti has implemented a series of significant initiatives, aimed at giving maximum visibility to such an important anniversary. Among all, a dedicated logo has been created, of modern inspiration but which strongly reaffirms the roots of the Milanese company, integrating the year of its foundation. This logo represents the synthesis of 60 years of adventures, challenges and triumphs that merge into an icon that embodies the vibrant soul of the city of Milan. A representative and tangible symbol of the glorious past of the Guerciotti star and of the promises that will be the leading actors of its tomorrow.





# I am Paolo Guerciotti. My story is also that of Italo, my brother.

He was older than me and was a very strong cyclocross rider: he passed on to me his passion for cycling and thanks to him I entered the world of competitive cycling until I opened the first Guerciotti bicycles shop in Milan, our city. Italo was a very skilled mechanic, while I was more inclined to sales. Together we represented a perfect tandem.



## A name that means Cycling

The Guerciotti family has been building bicycles for 60 years, branding every single product with their own name. A guarantee of absolute quality, derived from a passion passed down from father to son.

1964

Paolo and Italo Guerciotti - brothers and great cyclocross enthusiasts - open the first bicycle shop in Milan that bears their surname. A twenty square meter area that breathes cycling in all its forms.



2024

Over the next 60 years, the Guerciotti family built bikes that raced and won at the Giro d'Italia, while becoming a leading brand on the international market.





LANIFICIO  
**magniarredo**  
magniflex

G.S.  
**magniflex** MATERASSO A MOLLE  
**FAMCUCINE** cucine ponibili

Two men in suits standing on the left side of the team.

Two men in suits standing on the right side of the team.

Milan is fashion, industry,  
art, work, lifestyle.

Milan is trend.

And we want to build the  
most Milanese bicycles  
that exist.

## Winning tradition

Every family passes down its values from father to son. Today Alessandro and Micaela Guerciotti have joined their father Paolo in managing the company, preserving his work and thus ensuring a bright future. It is a new Guerciotti that faces this seventh decade of activity, strong in its past full of history, but also pervaded by infinite enthusiasm and an inexhaustible creative drive, which translate into unique products and extraordinary projects.







Constant  
commitment to the  
growth of young  
cyclists.

With its cyclocross team, the Guerciotti family has become an institution over the years, winning 81 titles to date, including 10 world championships and a world cup. Not only that, the Guerciotti team has launched some of the most talented young people in the history of this discipline. Guerciotti also supports the most important Italian youth road teams as a technical partner, collecting numerous victories in this area too.

# Guerciotti Bicycles: How does beauty arise?

Welcome to our atelier. Just like in the workshops of the most famous fashion houses, at Guerciotti we pay the utmost attention to the look to be sewn onto your next bicycle. The liveries of our special products, hand-painted, thus show off unique nuances.

The artist's touch: a very fine craftsmanship, an extremely manual craft that translates into never banal colors and finishes. We paint our special bicycles with a local supply chain, this guarantees us maximum control over each creation, which remains unrepeatable in its own way.

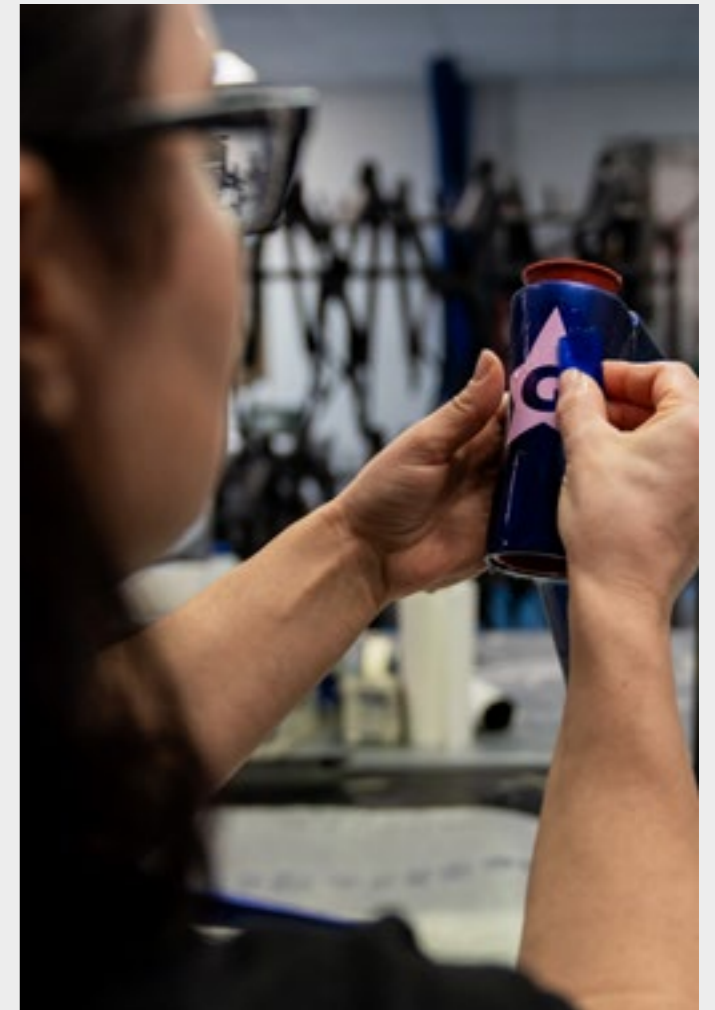

The work is complete. A careful in-house assembly certifies the construction excellence of Guerciotti bicycles. Each piece is the result of the unparalleled technical experience of our mechanics, of their expert hands. By choosing the stars of Milan you can count on a 60-year history of racing assembly and setup.

To celebrate our first sixty years of activity we have decided to tell this technical and creative attitude by launching a wide series of exciting colors that can be yours and yours alone, creating the perfect mix between top-level performance and an incomparable design.



A jewel that represents excellence in technique and design. Here is our Sixty.



A fully integrated system that offers a frame with unique aesthetics and aerodynamics on the market. A color that reflects the value of a product destined to be talked about for a long time. Sixty Limited Edition is made in 60 numbered pieces with gold finish. A non-limited edition model is also planned and available in two different colors, to give a wider audience the chance to experience the thrill of riding our jewel.



## Frame

A masterpiece of design, the frame features Mitsubishi T65 carbon tubes with a UD finish, to offer maximum rigidity and a racing set-up.

## Front End and Integrated Fork

The front end and fork are fully integrated. The absence of the fork tube provides for the fixing of the fork end with screws fixed to the bearings, for maximum stability in the ride.



## Aerodynamic Fork

The innovative design of the fork includes channels that facilitate the passage of air, maximizing the aerodynamics of the bike, further improving performance.



## Unique Rear Design

The rear triangle features a special blade-shaped design that adapts best to the airflow, minimizing friction and helping to increase aerodynamic performance.

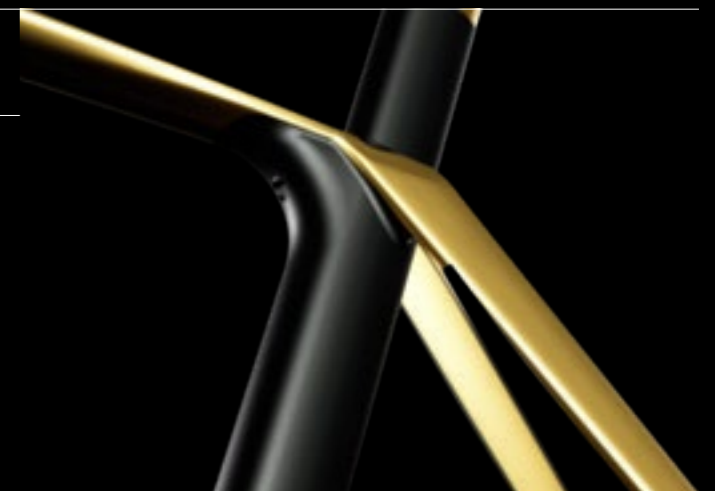



# Inspired by Milano



Exclusivity



Eclecticism

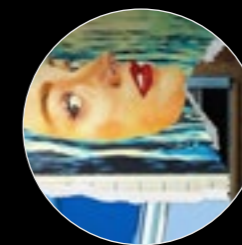

Prestige



Dynamism



Innovation

The heart of Italian taste beats in Milan, suspended between fashion, design, contemporary art and new digital trends. We present a capsule collection of bicycles with special paint finishes "Inspired By Milano", Guerciotti's homage to five different souls of our city that meet and contaminate each other, perpetuating Milanese culture in the world.

## Iconic Gold

In Piazza del Duomo, with your nose up, admiring the extraordinary beauties that embellish our city. The iconic "Madonnina", which dominates Milan, inspired the xirallica "Iconic Gold" paint job.



## Made in Milano

An aperitif at Camparino concludes a vibrant day at Fashion Week. The Milanese passion for all that is evoked by the "Made in Milano" chrome-plated paintwork.



## Crystal Ice

The streets of Milan are steeped in creativity, in a constant dialogue between art and design. The "Crystal Ice" paint represents the freshness of Milanese thought, suspended between design and decoration.



## Act of changing

A city in constant movement. The urban fabric changes skin accompanying the passage of time. Milan anticipates trends, the "Act of changing" painting embodies its transformist nature.



## Holographic Dream

Fast-moving, fluid, blurred images: young people looking for new forms of expression. A generational revolution is underway. The "Holographic Dream" paint job tells the story of the new Milan.



# Madame Project

The Guerciotti family has always supported all forms of cycling, acting as a technical partner for several women's development teams around the world. Thanks to the feedback obtained during the journey with our girls, we were able to develop a series of frames with geometries and sizes optimized for the female physical structure.

## Never be bored again

Life is never just black and white. Why should a bicycle be? Madame bikes are offered in a series of dedicated paint finishes inspired by the most interesting color trends in the fashion and interior design sectors.

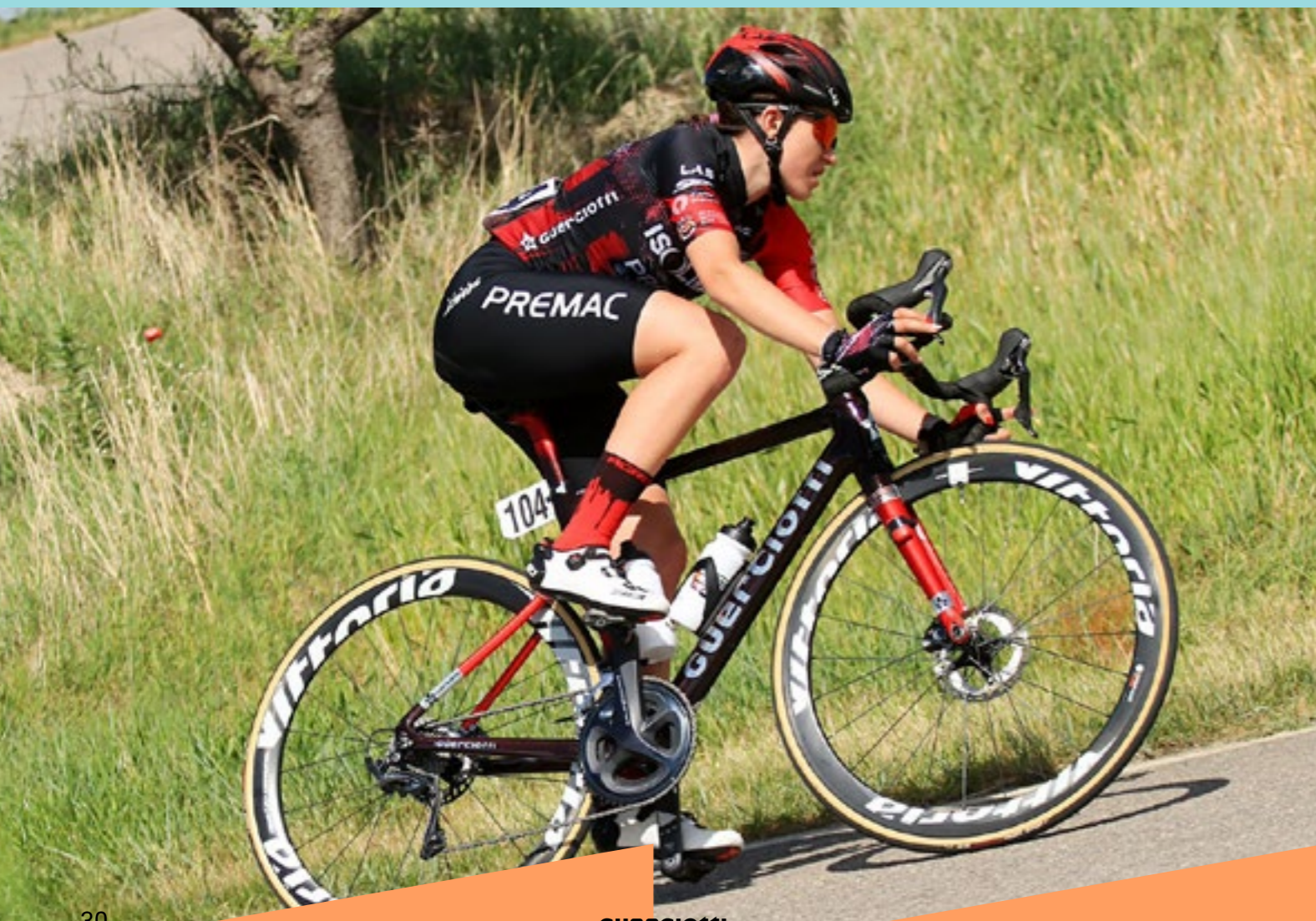

# Road Bike

## Eclipse S

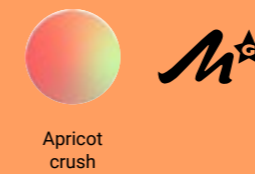
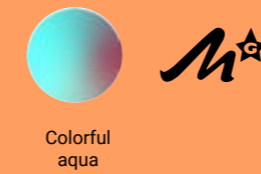



# I.ON Bike

Navir I.ON



Colorful aqua



# Ciclocross Bike

Silvelle



Colorful aqua



SAN BABILA





# Milano

Our first Urban e-bike celebrates the sixtieth anniversary of the Milan Metro. The bike features the colors, typography and shape of the metro handrail, paying homage to a work of art of Italian design.

The layout and signage of the Milan subway, designed by Bob Noorda and Franco Albini, are a masterpiece of visual communication. Their work has given a precise identity to the subway, making it easily usable by all users. The colors, typography and shape of the handrail have become distinctive elements recognized internationally and awarded the Compasso d'Oro in 1964, the year the Guerciotti brand was founded.

A constantly renewing partnership between the Guerciotti company and the city where it was born, demonstrating how both are driven by the same ideals of innovation and design and the same vision of the future, to give life to futuristic solutions destined to set trends.



THE "INFINITE" HANDRAIL

The theme of the curved tube, which becomes an "infinite" handrail, represents a key element in the design of the Milan metro, the work of Franco Albini and Franca Helg with Antonio Piva and graphics by Bob Noorda (1962-1964).



BOB NOORDA IN SAN BABILA STATION

Bob Noorda, in charge of the signage, used rationalist philosophy to create a clear and intuitive information system. It represents a highly distinctive element that still characterizes the red line of the Milan subway.



Milan encompasses a variety of worlds, shapes and colors. Our e-bike allows you to grasp all its nuances and fully experience the multifaceted soul of our city.



01  
amaranth



## Milano, your new urban e-bike

Milano is the new urban electric bike Guerciotti branded, which is inspired in its design by the distinctive character of the Milanese subway, born in 1964, the year in which the Guerciotti company was founded. With Milanese origins and urban inspiration, Milano represents a modern alternative to traditional mobility, offering a sustainable option for urban travel.

### Frame



### Trim

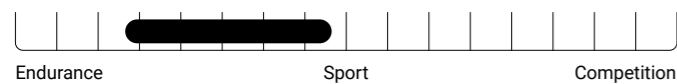

### Frame colors available

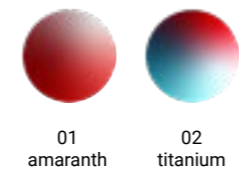

### Summing up

Use: **Urban**

Frame material: **Alloy**

Braking system: **Disc**

### Available sizes

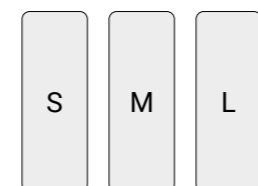

## Characteristics

Aluminum frame and carbon fork with a unique and identifying design

Mahle X35+ rear engine with a maximum assisted speed of 25 km/h

248Wh, 36V Panasonic battery

6V sequential Pinion gear change

Hydraulic disc brakes and belt transmission

Possibility of additional accessories such as luggage rack, child seat, bags

## What will you like?



### PINION pinion gear change

It allows extremely fast gear changes and with each use you immediately perceive the gear change. It minimizes accidental gear changes.



### Belt drive

The belt drive has a much longer life than a traditional chain. It also requires less maintenance and is very quiet.



### Distinctive design

Urban e-bike with a unique city-inspired style, suitable for both male and female users, enriched by a kit of useful accessories such as a basket, bell and stand.

## Mechanics

Rear engine	Mahle X35+
Battery	248Wh, 36V Panasonic
Pinion gear change	Pinion - Gearbox C1.6 Set

## Component

Pedals	Pedals EF102 Black
Saddle	Selle Royal Vivo Unitech Sport Ergo Man
Coverings	Pirelli Cycl-e DTs



01  
titanium



# E-Bikes

## The I.ON system

Polini E-P3+ GP	46
-----------------	----

## Road e-bikes

Navir I.ON	48
------------	----

Sempione I.ON	54
---------------	----

## Gravel e-bikes

Brera I.ON	57
------------	----

Greto I.ON 630	62
----------------	----

Greto I.ON	66
------------	----

## New

IDT5 System	70
-------------	----

Ambrosia	72
----------	----

Gaia	76
------	----





## You, in control: discover the I.ON system

With the I.ON line Guerciotti intends to introduce light, rigid and reliable bikes, but at the same time aims to open up new paths for you. Recovering from an injury, cycling with better-trained companions or simply treating yourself to a longer trip than usual: YOU are in control.

### Technological heart: Polini E-P3+

Powerful, light and compact engine. Equipped with an aeration filter, it allows access for lubrication of the gears and also provides the possibility of mounting the double crown. Speed, torque and pedaling frequency sensors, provision for cut-off and programming port.



**75 Nm**  
maximum torque

**500 watt**  
peak power

**2950 gr**  
weight

## 5 mappings of which 3 are pre-established and 2 are configurable

<b>Touring</b>	<b>Dynamic</b>	<b>Race</b>	<b>Custom 1</b>	<b>Custom 2</b>	<b>Walk Mode</b>
Sweet and progressive, ideal for daily use and longer autonomy.	With a sporty character, but at the same time natural and precise.	Without compromises, a real racing map, to offer maximum performance.	Fully configurable by the user via the smartphone app.		Do you push by hand? E-P3 allows you to proceed at 6 km/h with the simple press of a button.

## Electronics with Motorsport algorithm

The "Polini Dynamic Control" software was developed with 4 objectives.

Precision of assistance torque delivery always based on the effort applied by the cyclist on the pedals.	Responsiveness in following pedaling variations.	Reduction of the motor's response time when you start pedaling.	Increased active assistance up to 120 RPM.
--	--	---	--

## 500Wh lithium-ion battery

The integrated lithium-ion battery gives you an incredible range of 220 km in standard conditions. This is made possible by its 500 Wh and the advanced software that delivers the torque intelligently.



### Autonomy

• With dynamic map on road bikes • Average pedaling frequency 60-80 rpm  
• Rider weight 60-80 kg • Average speed range 20/25 km/h • Flat route

Assistance level 1 - help assistance 30%:	Autonomy 180/220 km
Assistance level 2 - help assistance 60%:	Autonomy 150/180 km
Assistance level 3 - help assistance 120%:	Autonomy 100/150km
Assistance level 4 - help assistance 250%:	Autonomy 80/100km
Assistance level 5 - help assistance 400%:	Autonomy 60/85 km



### TFT Display

2.5-inch color screen with adaptive light that shows the cyclist's pedaling power, cadence, motor power and residual range.

1.45" microdisplay integrated into the frame available on the GRETO 630 ION model.

Download the Polini E-Bike App:





# Navir I.ON





MAD01  
colorful aqua



## Navir I.ON. Passion without limits

There are several reasons to choose an electric racing bike like Navir I.ON. It can help you recover your condition after an injury. It allows you to go out with more trained companions. It opens the way to previously unimaginable goals. Why put limits on passion?

### Frame



### Trim



### Frame colors available

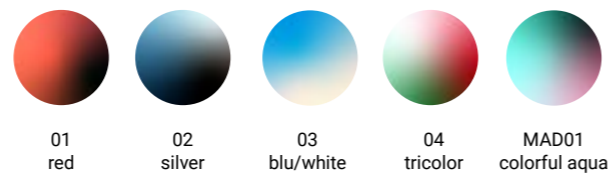

### Summing up

Use: **Road**

Frame material: **Carbon**

Braking system: **Disc**

### Available sizes

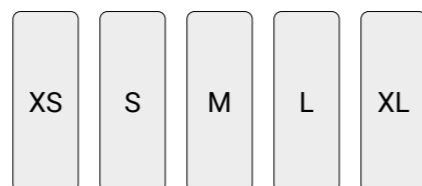

## Characteristics

Carbon monocoque racing frame with integrated battery pack

500 watt Polini E-P3+ GP electric motor, with maximum torque of 75 N/m

500 wh battery with autonomy in assisted mode of up to 220 km (see table on page 47)

5 selectable assistance levels and assisted walking mode

Cables integrated inside the stem and handlebar

## What will you like?

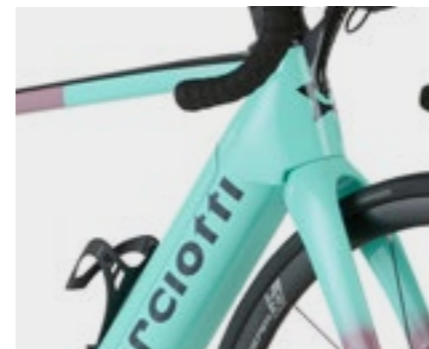

### Frame

Carbon frame produced in a unique mold using a mix of top quality Japanese fibres. Reinforced in the most stressed points and kept as rigid as possible.



### E-P3+ GP electric motor

Polini electric motor. Powerful, light and discreet, it assists you up to 25 km/h. Built-in lithium ion battery.



### Handlebar

The cables are hidden inside the stem and handlebar. This improves aerodynamics, while giving you an aesthetically stunning frame.

## Frame

Fork: Monocoque

Headset: oversize (1-1/8 - 1-1/2)

Seatpost: 27,2

Thru axles: ✓

Flat mount: ✓

Electronic groups preparation: ✓

## Components

Pedals: Not included

Saddle: Selle Italia Model X

Seatpost: QTC Energy

Stem: QTC Carbon

Handlebar: QTC Energy

Tires: Michelin Power Cup

Bottle cage: Not included

## Mounting options

Groupset: Shimano 105 7020 11v  
Shimano 105 7170 12v di2  
Shimano Ultegra 8020 11v

Wheels: Vision Team 30 AGX i23  
Vision SC40 Carbon



01  
red



03  
blu/white



02  
silver



04  
tricolor



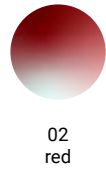

02  
red



## Sempione I.on. Switch to electric

All our experience, electrified. With Sempione I.ON we put you in the saddle of a racing bicycle designed to reproduce the traditional pedaling feeling signed by Guerciotti, adding the convenience represented by pedal assistance.

### Frame

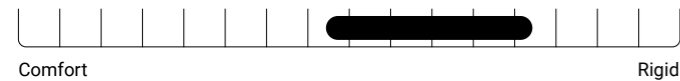

### Trim

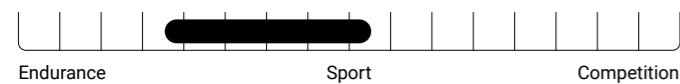

### Frame colors available

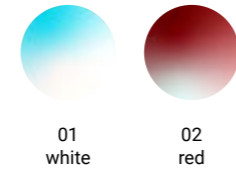

01  
white

02  
red

### Summing up

Use	Frame material	Braking system
Road	Aluminum	Disc

### Available sizes

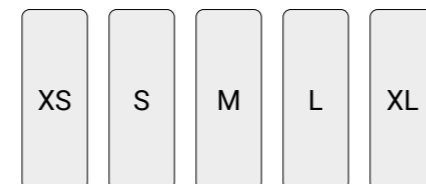

## Characteristics

Aluminum racing frame with integrated battery pack

500 watt Polini E-P3+ GP electric motor, with maximum torque of 75 N/m

500 wh battery with autonomy in assisted mode of up to 220 km (see table on page 47)

5 selectable assistance levels and assisted walking mode

Cables integrated inside the stem and the handlebar

## What will you like?

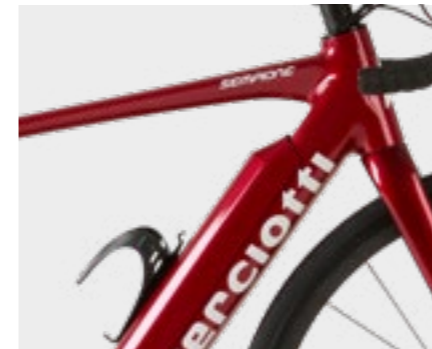

### Frame

Made with 7000 alloys heat treated at the end of welding to bring the state of the aluminum back to T-0, making the frame extremely resistant.



### E-P3+ GP electric motor

Polini electric motor. Powerful, light and discreet, it assists you up to 25 km/h. Built-in lithium ion battery.



### Fork

Carbon fiber fork in double layer lamination to ensure high safety.

## Frame

Fork Carbon

Headset oversize (1-1/8 - 1-1/2)

Seatpost 27,2

Thru axles ✓

Flat mount ✓

Electronic groups preparation ✓

## Components

Pedals Not included

Saddle Selle Italia X1

Seatpost QTC Energy

Stem FSA Omega

Handlebar FSA Vero

Tires Vittoria Zaffiro Pro

Bottle cage Not included

## Mounting options

Groupset Shimano 105 7020 11v  
Shimano Ultegra 8020 11v

Wheels Ursus Orion disc alloy

01  
white



# Brera I.0N



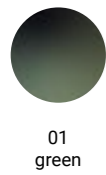

01  
green

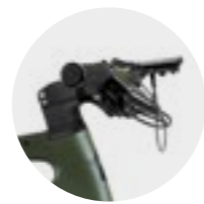

Available with  
flat handlebar

# Brera I.ON. Every road is your road

Rediscover the true essence of Gravel. Live between asphalt and dirt, never stop exploring. Find your destination, but don't forget to enjoy the ride. This is your time, your world. Don't let them tell you what's best for you. Choose your path: have fun, with Brera I.ON.

## Frame



## Trim

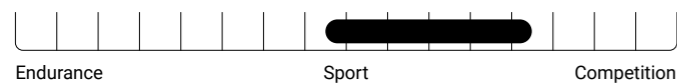

## Frame colors available

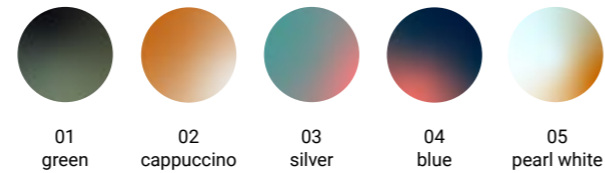

## Summing up

Use	Frame material	Braking system
Gravel	Carbon	Disc

## Available sizes

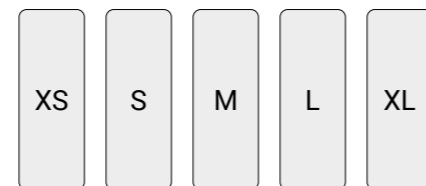

## Characteristics

Carbon monocoque gravel frame with integrated battery pack

Polini E-P3+ GP 500 watt electric motor, with maximum torque of 75 N/m

500 wh battery with autonomy in assisted mode of up to 220 km (see table on page 47)

5 selectable assistance levels and assisted walking mode

Bag eyelets on the front fork and rear stay

## What will you like?



### Frame

Reinforced in the areas of maximum torsion to obtain an elastic but at the same time rigid bike when relaunching the pedal stroke. Comfortable and suitable for slopes.



### E-P3+ GP electric motor

Polini electric motor. Powerful, light and discreet, it assists you up to 25 km/h. Built-in lithium ion battery.

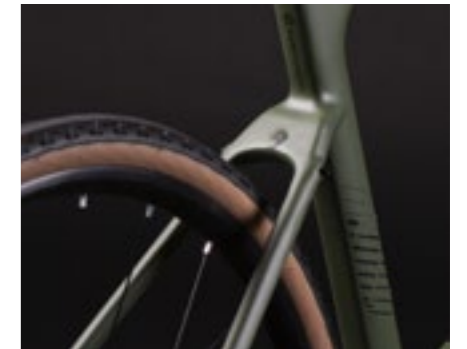

### Eyelets for bike packing

Through the special eyelets, positioned on the front fork and on the rear stay, Brera I.ON can accommodate your bags and up to two water bottles.

## Frame

Fork Carbon

Headset Oversize (1-1/2 - 1-1/2)

Seatpost Brera I.ON

Thru axles ✓

Flat mount ✓

Electronic groups preparation ✓

## Components

Pedals Not included

Saddle San Marco Monza

Seatpost Brera I.ON

Stem QTC Carbon

Tires Challenge Gravel Grinder Comp

Bottle cage Not included

## Mounting options

Groupset Shimano GRX 400 2x10  
Shimano GRX 600 1x11  
Shimano GRX 600 2x11  
SRAM Apex AXS 1x12  
SRAM NX 1x11\*

Handlebar FSA Adventure  
QTC Flat Touring\*

Wheels Ursus Orion Disc Alloy  
Ursus C37 Carbon TLR

\*only for Touring version



02  
cappuccino



Available with  
flat handlebar



04  
blue



Available with  
gravel handlebar



03  
silver

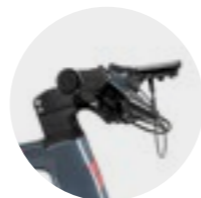

Available with  
flat handlebar



05  
pearl white

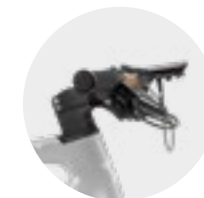

Available with  
flat handlebar

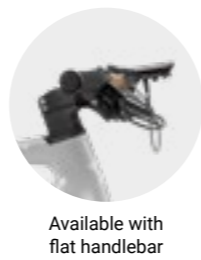

# Greto I.ON 630. Expand the adventure

Greto ION 630 represents the upgrade of Greto ION. Its new version, made even more performing thanks to the use of the 630 watt battery, is also characterized by a revised and even more modern design, which allows the cyclist to obtain better performance and greater comfort in pedaling. All enriched by a more attractive aesthetic, aimed at better expressing its gravel soul.

## Frame



## Trim



## Frame colors available

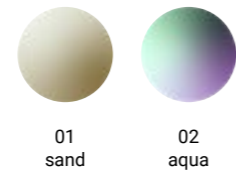

## Summing up

Use	Frame material	Braking system
Gravel	Alluminio	Disco

## Available sizes

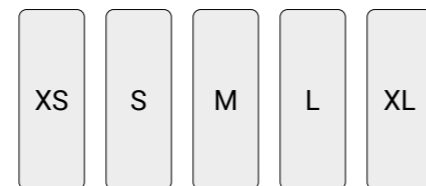

## Characteristics

Aluminum frame and carbon fork

500 watt Polini E-P3+ GP electric motor, with a maximum torque of 75 N/m

630 wh battery with autonomy in assisted mode up to 220 km (see table on page 47)

5 levels of assistance and assisted walk mode selectable

Bag holder eyelets on the front fork and rear triangle

## What will you like?



### Frame

Frame revised in design to offer greater comfort in pedaling. The eyelets for bike packing allow the housing of bags to place no limits on your desire for adventure.



### E-P3+ GP Electric Motor

Polini electric motor. Powerful, light and discreet, it assists you up to 25 km/h. Integrated lithium-ion battery.



### Microdisplay

Integrated display designed for complete union with the frame. Its small size and the 1.45-inch high-brightness, high-resolution TFT color screen ensure easy viewing of information.

## Frame

Fork	Carbon
Headset	oversize (1-1/8 - 1-1/2)
Seatpost	QTC Razer
Thru axles	✓
Flat mount	✓
Electronic groups preparation	✓

## Components

Pedals	Not included
Saddle	San Marco Monza
Seatpost	QTC Razer
Stem	FSA V-drive
Tires	Challenge Gravel Grinder Comp
Bottle cage	Not included

## Mounting options

Groupset	Shimano GRX 400 2x10 Shimano GRX 600 1x11 Shimano GRX 600 2x11 SRAM Apex AXS 1x12 SRAM NX 1x11*
Handlebar	FSA Adventure QTC Flat Touring*
Wheels	Ursus Orion Disc Alloy

\*only for Touring version





02  
aqua

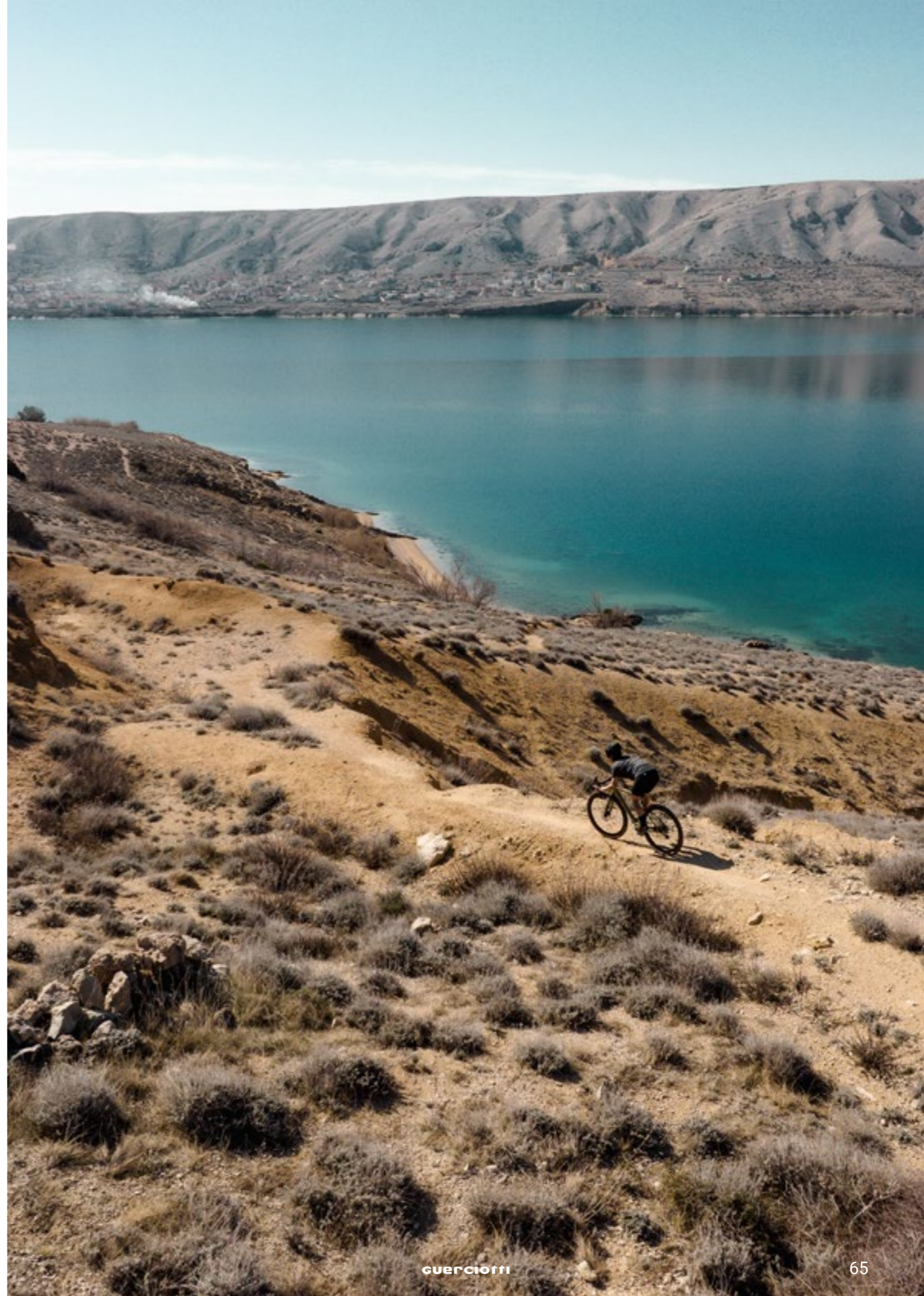

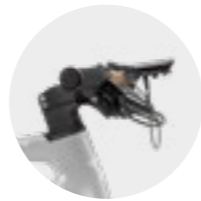
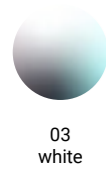

Available with flat handlebar



## Greto I.ON. Expand the adventure

Greto I.ON represents the electrified version of our Greto. A bike intended for gravel use with aluminum frame and carbon fork. This bike is a valid alternative to its bigger sister Brera I.ON, with which it shares a cyclocross-derived sporting spirit and high comfort of use.

### Frame



### Trim



### Frame colors available

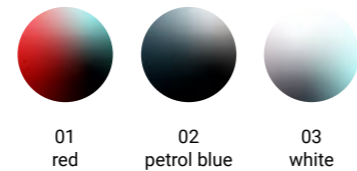

### Summing up

Use	Frame material	Braking system
Gravel	Aluminum	Disco

### Available sizes

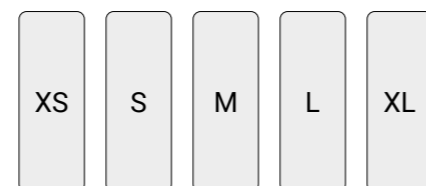

## Characteristics

Aluminum frame and carbon fork

Polini E-P3+ GP 500 watt electric motor, with maximum torque of 75 N/m

500 wh battery with autonomy in assisted mode of up to 220 km (see table on page 47)

5 selectable assistance levels and assisted walking mode

Bag eyelets on the front fork and rear stay

## What will you like?



### Frame

Frame in aluminum and fork in carbon, two characteristics which combined with the specific geometries for gravel usage, make the Greto I.ON the perfect bike for long adventures on all types of terrain.



### E-P3+ GP electric motor

Polini electric motor. Powerful, light and discreet, it assists you up to 25 km/h. Built-in lithium ion battery.



### Display

All data relating to the Polini engine and the bike are perfectly visible thanks to the 2.5-inch color display, capable of adapting the brightness based on the lighting conditions, to allow reading at any time.

## Frame

Fork	Carbon
Headset	oversize (1-1/8 - 1-1/2)
Seatpost	QTC Razer
Thru axles	✓
Flat mount	✓
Electronic groups preparation	✓

## Components

Pedals	Not included
Saddle	San Marco Monza
Seatpost	QTC Razer
Stem	FSA V-drive
Tires	Challenge Gravel Grinder Comp
Bottle cage	Not included

## Mounting options

Groupset	Shimano GRX 400 2x10 Shimano GRX 600 1x11 SRAM NX 1x11*
Handlebar	FSA Adventure QTC Flat Touring*
Wheels	Ursus Orion Disc Alloy

\*only for Touring version



01  
red



Available with  
flat handlebar



02  
petrol blue



Available with  
flat handlebar



# Intelligent Drive Tech: Discover our new IDT5 system.

IDT5 is an innovative system that doubles the autonomy thanks to two separate batteries, maintaining maximum discretion. The 3.5" display is positioned on the central tube, while the handlebar controls allow you to manage all the functions without ever taking your hands off. The entire pedal stroke can be monitored and optimized via a dedicated app, which offers all the information necessary for total control and a 100% smart driving experience.

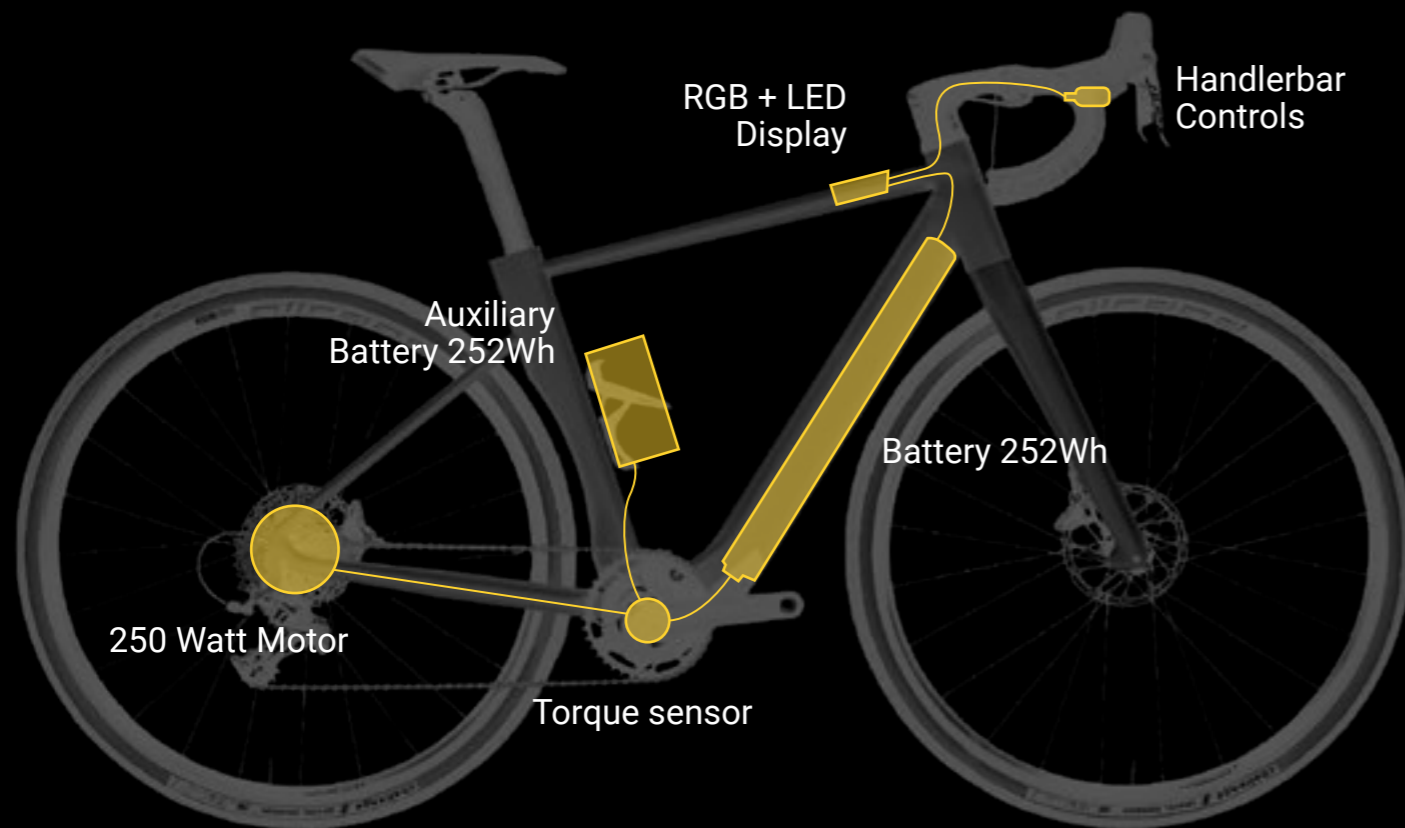

## iDT Controller

The heart of the technology behind the iDT system is the controller and its firmware algorithm. The controller is the brain of the e-bike and coordinates all peripheral components connected to it. In particular, the intelligent management of the two batteries takes current from where it is most appropriate. Contrary to most controllers on the market, which use the second battery to charge the main one, the parallel management of the iDT allows you to avoid overloading and excessive discharge currents as much as possible.



## App iDT

Connect via Bluetooth and control the entire system via the dedicated app available for free on the Play Store or App Store. Residual battery charge, instant speed, average speed, power output and many other configurations to make your Guerciotti iDT experience smart in every aspect.



## 250 Watt Motor

The rear motor, weighing only 1.9kg, delivers a torque of 42Nm to the axle. Its low weight and small size make it perfect for racing and gravel applications. Available in a 12x142mm thru-axle version, it features an interchangeable Shimano HG 9v/12v cassette.

## Battery 252Wh

Battery managed by Battery Management System, which will guarantee maximum efficiency and duration over time. It mounts Panasonic cells.



## Auxiliary battery 252 Wh

Battery with mirror-image features to the main one, camouflaged as a water bottle to maintain discretion, the basis of the philosophy of the entire project.



## Torque sensor

For a maximum feeling of naturalness, the sensor is integrated into the bottom bracket instead of the engine. The torque measurement is taken directly in proportion to the muscular effort, before the bicycle's gear ratio alters its value. ISIS type crankset attachment.



## Handlebar controls

Controls that integrate perfectly into the handlebars and allow you to change the level of assistance without ever taking your hands off the bike. Waterproof level IP67.



## RGB + LED Display

The 3.5" display allows a non-intrusive experience to monitor both the charge level, graduated by 5 light bars, and the assistance level, through 3 different colors. It can communicate with its App through the Bluetooth protocol and dialogues with the rest of the system via Canbus. Waterproof level IP67, it is not afraid of atmospheric agents.



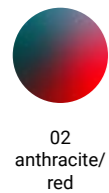

02  
anthracite/  
red



## Ambrosia, recharge with new energy

Ambrosia is the new Guerciotti e-bike equipped with the new Intelligent Drive Tech (IDT5) rear motor, applied to the hub. A bike with an aluminum frame and a very responsive carbon fork, with good performance and an excellent quality/price ratio, ideal for giving more grit to your rides in company, and to guarantee you a more sustainable form of transport.

### Frame

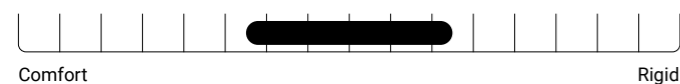

### Trim



### Frame colors available

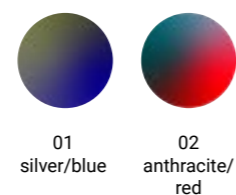

### Summing up

Use: **Road**    Frame material: **Alumimun**    Braking system: **Disc**

### Available sizes

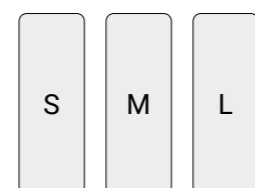

## Characteristics

250 watt Intelligent Drive Tech rear hub motor

250 watt battery with Panasonic cells managed by Battery Management System

250 watt auxiliary battery camouflaged as a bottle cage

3.5" RGB LED display applied to the frame

Controls perfectly integrated into the handlebars

Cable integration to offer a modern and clean design



### Display Led RGB

The display allows you to monitor the charge level, graduated by 5 light bars, and the assistance level, through three different modes.



### Handlerbar Control

Controls perfectly integrated into the handlebars that allow you to change the level of assistance without ever taking your hands off the wheel.

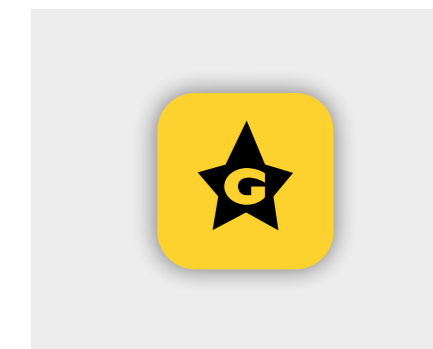

### Guerciotti IDT App

Free to download from Apple Store and Google Play to monitor the remaining battery charge, instant speed, average speed, power output, to make pedaling 100% smart. Possibility of unlocking the engine via App.

### Frame

Fork: Carbon

Headset: Oversize (1-1/2 - 1-1/2)

Seatpost: QTC Energy

Thru axles: ✓

Flat mount: ✓

Electronic groups preparation: ✓

### Components

Pedals: Not included

Saddle: San Marco Monza

Seatpost: QTC Energy

Stem: QTC Alloy

Handlebar: QTC Energy

Tires: Vittoria Zaffiro Pro

Bottle cage: Not included

### Mounting options

Groupset: Shimano 105 R7020 11V  
Shimano Ultegra 8020 11v

Wheels: QTC Alloy

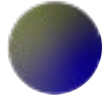

01  
silver/blue



01  
Sage



## Gaia, your new off-road partner

Gaia is the gravel version of the new Guerciotti e-bike model developed with the new Intelligent Drive Tech (IDT5) motor applied to the hub. Aluminum frame and carbon fork, thanks to the use of the rear motor, this bicycle is very responsive while maintaining a low cost.

### Frame

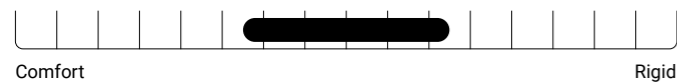

### Trim



### Frame colors available

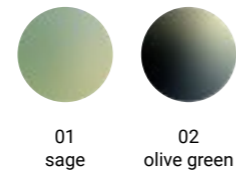

### Summing up

Use	Trim material	Braking system
Gravel	Alumimun	Disc

### Available sizes

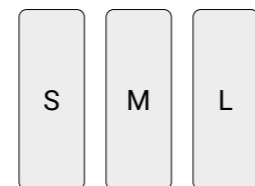

## Characteristics

250-watt Intelligent Drive Tech hub-mounted rear motor and 250-watt battery

250 watt auxiliary battery camouflaged as a bottle cage

3.5" RGB LED display applied to the frame

Handlebar controls and cable integration for a clean, modern design

Eyelets to accommodate bags and bottle cages

Possibility to fit tyres up to 45 mm



### Handlebar Control

Controls perfectly integrated into the handlebars that allow you to change the level of assistance without ever taking your hands off the wheel.

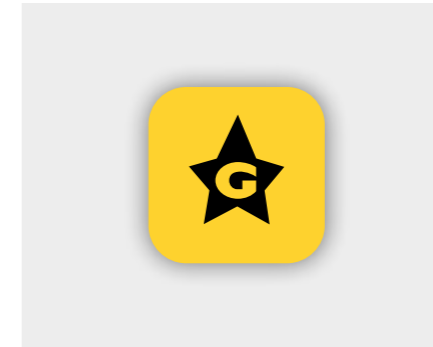

### Guerciotti IDT App

Downloadable for free from the Apple Store and Google Play to monitor the remaining battery charge, instant speed, average speed, power output, to make pedaling 100% smart.



### Eyelets for bike packing

Through the special eyelets, positioned on the front fork and on the rear stay, GAIA can accommodate your bags and up to two water bottles.

### Frame

Fork	Carbon
Headset	Oversize (1-1/2 - 1-1/2)
Seatpost	QTC Raizer
Thru axles	✓
Flat mount	✓
Electronic group preparation	✓

### Components

Pedal	Not included
Saddle	San Marco Monza
Seatpost	QTC Raizer
Stem	QTC Alloy
Handlebar	FSA adventure
Tires	Challenge Gravel Grinder 38
Bottle cage	Not included

### Mounting options

Groupset	Shimano GRX 400 2x10 Shimano GRX 600 1x11
Wheels	QTC Alloy



02  
olive  
green



# Road

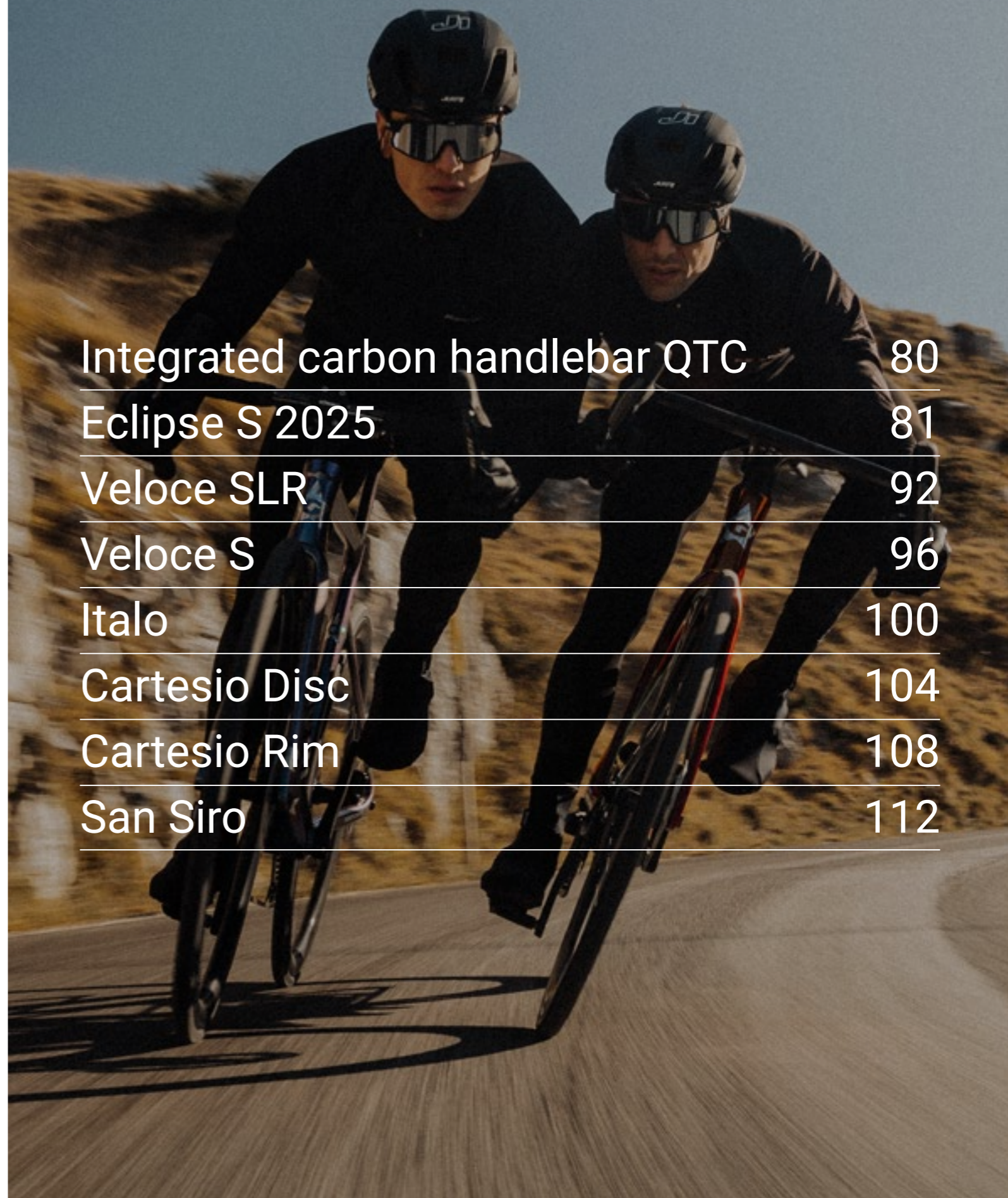

Integrated carbon handlebar QTC	80
Eclipse S 2025	81
Veloce SLR	92
Veloce S	96
Italo	100
Cartesio Disc	104
Cartesio Rim	108
San Siro	112





# Eclipse S 2025

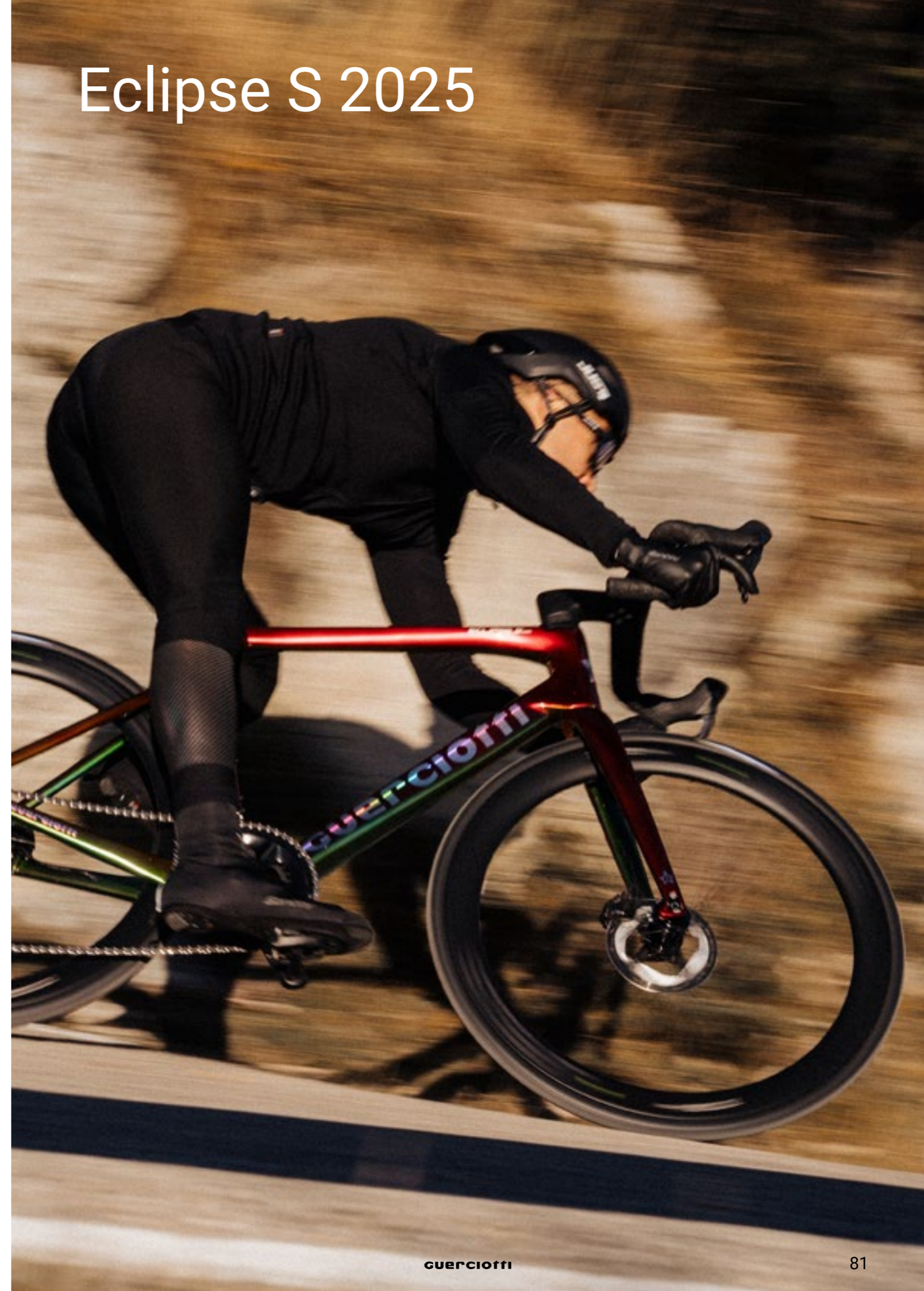

## QTC Carbon Integrated Handlebar

Guerciotti's exclusive integrated handlebar is completely made of carbon. Through the ACR system that combines the headset and handlebar we can have a perfect integration of the cables, also extended to the fork. In fact, this handlebar is offered with a frame kit. Linear and clean design.

Drop	Reach	Length	Width	Length	Width
127mm	76mm	90 mm	400 mm	110 mm	420 mm
		100 mm	400 mm	120 mm	420 mm
		100 mm	420 mm	120 mm	440 mm
		110 mm	400 mm	130 mm	420 mm
Length	Width				
90 mm	380 mm				

Available on					
Eclipse S	Veloce SLR	Escape	Veloce S	Eureka CXS	Italo Disc

\* Handlebar dimensions are c-c



06  
Green metal



730 g  
frame weight

110 kg  
Weight Limit

## Characteristics

New Mitsubishi T65 tubes with UD finish for maximum chassis rigidity and reliability

New dropout with UDH system for high resistance

Handlebar with internal cable routing, perfectly integrated into the frame

Latest generation braking system, with disc brakes and flat mount calipers

Thru-axle hubs for an extremely rigid setup

## What will you like?

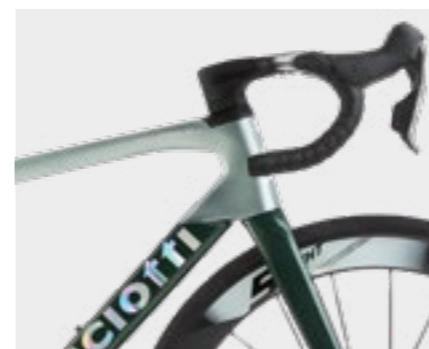

### Extremely rigid setup

Frame made with Mitsubishi T65 tubes extremely light but with a higher breaking load of the material per mmq from 850 to 1350.



### Dropout with UDH system

The use of the new UDH dropout system, which is characterised by greater solidity and resistance, offers greater stability to the frame.

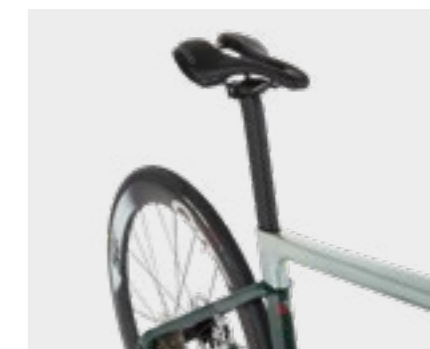

### Seatpost in 3 versions

The Eclipse S 2025 seatpost is available in 3 offset versions: 0, -10 mm, -25 mm to respond specifically to the different user seating needs.

# Eclipse S 2025: Competitive Soul

Eclipse S 2025 represents the evolution of the most performing racing model in the Guerciotti range. An exclusive bike in its frame and look, enriched by a new extremely distinctive graphic design and refined colors, to which is added the possibility of choosing the new customized paints "Inspired by Milano".

## Frame



## Trim



## Frame colors available

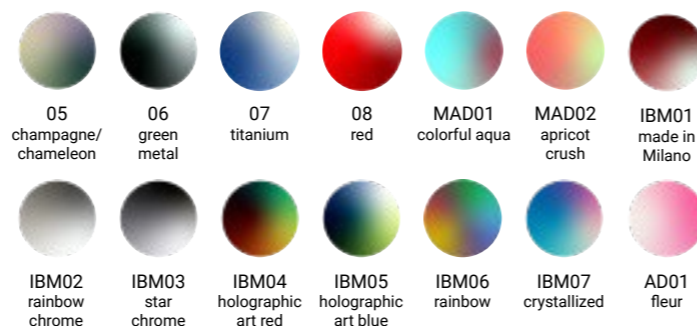

## Available sizes

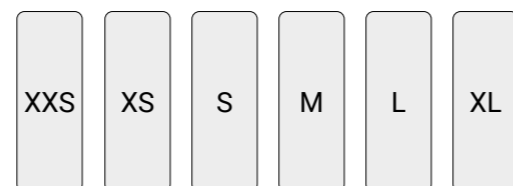

## Summing up

Use	Frame material	Braking system
Road	Carbon	Disc

## Trim

Fork Carbon monocoque

Headset Oversize (1-1/2 - 1-1/2)

BB Shell Press-Fit

Seatpost Carbon Eclipse S

Thru axles ✓

Flat mount ✓

Electronic groups preparation ✓

## Components

Pedals Not included

Saddle QTC RS Carbon

Seatpost Eclipse S

Stem QTC integrated carbon

Handlebar QTC integrated carbon

Tires Vittoria Corsa Next

Bottle cage Not included

## Mounting options

Groupset Shimano Ultegra 8170 12v di2  
Shimano Dura Ace 9270 12v di2  
SRAM Red AXS 2x12 di2

Wheels Vision Team 30 AGX i23  
Vision Metron 45 SL Carbon TLR  
Ursus TC47 Carbon TLR  
QTC SL Light Carbon  
QTC Hurricane Carbon



05  
champagne/  
chameleon



08  
red



07  
titanium



IBM01  
made in  
Milano





IBM02  
rainbow  
chrome



IBM04  
holographic  
art red



IBM03  
star  
chrome



IBM05  
holographic  
art blue





IBM06  
rainbow

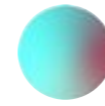

MAD01  
colorful aqua



IBM07  
crystallized



MAD02  
apricot  
crush





AD01  
fleur





890 g  
frame weight

---

110 kg  
Weight Limit

## Characteristics

Mitsubishi T45 carbon tubes with UD finish

T47 BSA bottom bracket

Widened head tube for improved aerodynamics

New dropout with UDH system for high resistance

Seatpost available in 3 versions

## What will you like?



### Maximum stability

Veloce SLR uses new Mitsubishi T45 tubing which increases frame stiffness compared to the Veloce S model, improving performance and speed.

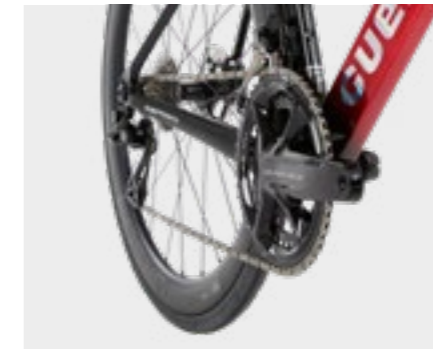

### T47 BSA bottom bracket

The T47 threaded bottom bracket helps increase frame stiffness and allows for the fitment of any type of crankset.



### Seatpost in 3 versions

Veloce SLR seatpost is available in 3 offset versions: 0, -10 mm, -25 mm to specifically respond to the different seating needs of the user.

# Veloce SLR, power and control

Veloce SLR represents the evolution of one of Guerciotti's most beloved models, characterized by a strong racing soul and top-level performance, thanks to the use of new materials and new shapes enriched by an attractive design that reveals the new carbon finish applied to the rear triangle.

## Frame



## Trim



## Frame colors available

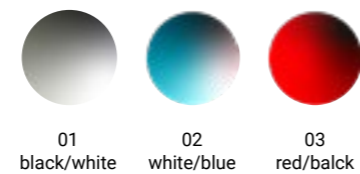

## Summing up

Use	Frame Material	Braking system
Road	Carbon	Disc

## Available sizes

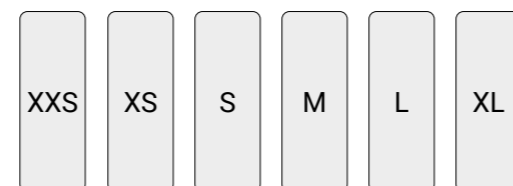

## Frame

Fork	Carbon
Headset	Oversize (1-1/8 - 1-1/2)
BB Shell	T47 BSA
Seatpost	Carbon Veloce SRL
Thru axles	✓
Flat mount	✓
Electronic groups preparation	✓

## Components

Pedals	Not included
Saddle	Selle Italia SLR Boost Manganese
Seatpost	Veloce SLR
Stem	QTC Carbon
Handlebar	QTC Energy
Tires	Michelin Power Cup
Bottle cage	Not included

## Mounting options

Groupset	Shimano Ultegra 8170 12v di2 Shimano Dura Ace 9270 12v di2 SRAM Red AXS 2x12 di2
Wheels	Vision Team 30 AGX i23 Vision SC55 Carbon TLR Vision SC40 Carbon TLR Ursus TC47 Carbon TLR



01  
black/white



02  
white/blue







1070 g  
frame weight

110 kg  
Weight Limit

## Characteristics

Monocoque carbon fiber frame

Carbon seatpost specific for the frame

Disc brake and wheels with thru axle for a high-performance bike even downhill

The tempered aluminum insert that houses the pin thread is interchangeable

## What will you like?



### Transmission

Available with Groupset Shimano Ultegra or 105 electronic which ensure precise shifting even when pushing.



### Disk brakes

Hydraulic disc brake for precise and powerful braking in all conditions. Braking a few meters from the hairpin will no longer be a problem, even in wet conditions.

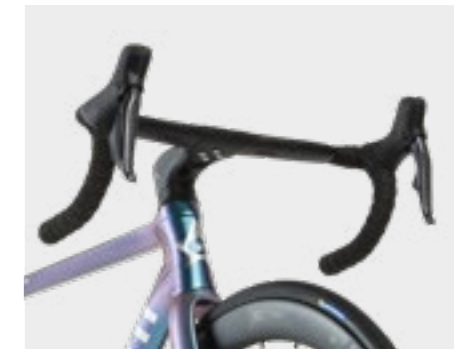

### Integrated QTC handlebar

Integrated QTC Carbon handlebar with internal cable routing available on request in all different versions.

# Veloce S. Designed for racing

Full carbon racing bike with top-of-the-range features, offered at a competitive price. Equipped with disc brakes and internal cable routing, this bicycle attracts the attention of all cyclists, thanks to the design and sinuous lines that distinguish it. Veloce S is the ideal choice for a cyclist who doesn't want to stop dreaming, setting himself increasingly ambitious goals.

## Frame



## Trim

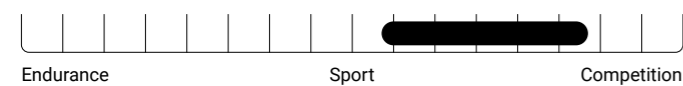

## Frame colors available

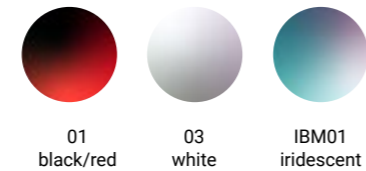

## Summing up

Use	Frame material	Braking system
Road	Carbon	Disc

## Available sizes

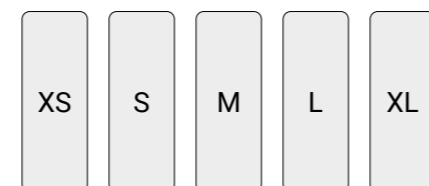

## Frame

Fork	Carbon
Headset	oversize (1-1/2 - 1-1/2)
BB Shell	Press-Fit
Seatpost	Carbon Veloce S
Thru axles	✓
Flat mount	✓
Electronic groups preparation	✓

## Components

Pedals	Not included
Saddle	Selle Italia Model X
Seatpost	Veloce S
Stem	QTC carbon
Handlebar	QTC Energy
Tires	Michelin Power Cup
Bottle cage	Not included

## Mounting options

Groupset	Shimano 105 7120 12v Shimano 105 7170 12v di2 Shimano Ultegra 8020 11v Shimano Ultegra 8170 12v di2
Wheels	Vision Team 30 AGX i23 Vision SC55 carbon TLR Vision SC40 carbon TLR Ursus TC47 carbon TLR



01  
black/red



03  
white





**1100 g**  
Frame weight

**110 kg**  
Weight Limit

## Characteristics

Carbon endurance frame, designed to reduce cyclist fatigue

Possibility of mounting 28 mm tires

The particular geometry of the frame gives stability on rough terrain

Latest generation braking system, with disc brakes and flat mount calipers

Hubs with thru axle, for an extremely rigid setting

## What will you like?



### Concealed cables

Italo's head angle is smaller than a normal racing model. This, accompanied by the geometries of the horizontal tube (shorter) and head tube (higher), leads to obtaining an overall longer frame and therefore more stable on rough surfaces.



### Vertical rear

The particular design of the vertical rears is studied to absorb vibrations even on rough terrain, in the case of cobblestones or dirty roads.



### Disk brakes

The disc brake solution allows you to brake in absolute safety. The design of the fork and frame has been renewed to make them compatible with the disc brake standard

# Italo. Comfortable for endurance rides

Italo is an endurance bike, dedicated to the memory of our co-founder Italo Guerciotti. It is a less extreme model than a traditional racing bike but equally high-performance and rigid when pedaling. Equipped with disc brakes.

## Frame

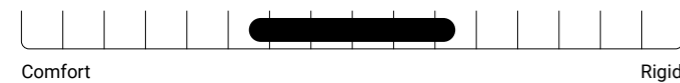

## Trim



## Frame colors available

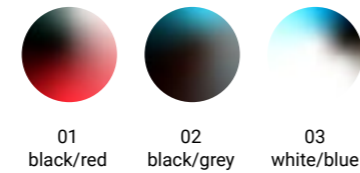

## Summing up

Use	Frame material	Braking system
Road	Carbon	Disc

## Available sizes



## Frame

Fork	Carbon
Headset	oversize (1-1/2 - 1-1/2)
BB Shell	Press-Fit
Seatpost	Carbon Italo Disc
Thru axles	✓
Flat mount	✓
Electronic groups preparation	✓

## Components

Pedals	Not included
Sella	Selle Italia Model X
Seatpost	Italo Disc
Stem	QTC carbon
Handlebar	QTC Energy
Tires	Vittoria Zaffiro Pro
Bottle cage	Not included

## Mounting options

Groupset	Shimano 105 7120 12v Shimano 105 7170 12v di2 Shimano Ultegra 8020 11v
Wheels	Vision Team 30 AGX i23 Vision SC40 Carbon TLR QTC Syntax



02  
black/grey



03  
white/blue



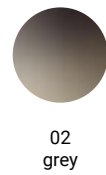

02  
grey



1020 g  
Frame weight

120 kg  
Weight Limit

## Characteristics

Carbon racing frame, well balanced between lightness and rigidity

Cable passage inside the frame

Predisposition for electronic groups

Possibility of mounting wide sprockets

Latest generation braking system, with disc brakes and flat mount calipers

Hubs with thru axle, for an extremely rigid setting

## What will you like?



### Concealed cables

For Cartesio we have adopted an internal cable routing system: this makes the bike as beautiful as a flagship. The frame's predisposition for electronic groupsets places Cartesio a step higher than common entry level models.



### Rear

The design of the rear is studied to ensure greater rigidity. It is also possible to mount wide sprocket packs. An important upgrade for young cyclists, who often need to use an 18 gear at the start.



### Disk brakes

The disc brake solution allows you to brake in absolute safety. The design of the fork and of the frame has been renewed to make them compatible with the disc brake standard.

# Cartesio Disc. For the champions of tomorrow

Your first step towards the Olympus of cycling. Cartesio Disc is a top-of-the-range carbon racing bicycle, designed to stand out among its competitors for its reactivity and performance.

## Frame

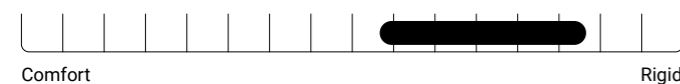

## Trim



## Frame colors available

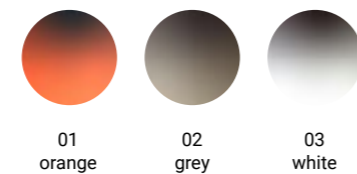

## Summing up

Use	Frame material	Braking System
Road	Carbon	Disc

## Available sizes

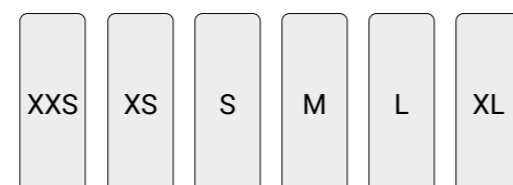

## Frame

Fork in carbonio

Headset Oversize (1-1/2 - 1-1/2)

Mounting options Press-Fit

Seatpost 27.2

Thru axles ✓

Flat mount ✓

Electronic groups preparation ✓

## Components

Pedals Not included

Saddle San Marco Monza

Seatpost QTC Energy

Stem QTC Alloy

Handlebar QTC Energy

Tires Vittoria Zaffiro Pro

Bottle cage Not included

## Mounting options

Groupseat Shimano 105 7120 12v  
Shimano 105 7170 12v di2  
Shimano Ultegra 8020 11v

Wheels Vision Team 30 AGX i23  
Vision SC40 Carbon TLR  
QTC Syntax



01  
orange



03  
white



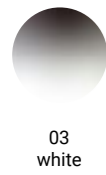

**980 g**  
Frame weight

---

**120 kg**  
Weight Limit

## Characteristics

Carbon racing frame, well balanced between lightness and rigidity

Cable passage inside the frame

Predisposition for electronic groups

Possibility of mounting wide sprockets

## What will you like?



### Concealed cables

For Cartesio we have adopted an internal cable routing system: this makes the bike as beautiful as a flagship. The frame's predisposition for electronic groupsets places Cartesio a step higher than common entry level models.



### Rear

The design of the rear is studied to ensure greater rigidity. It is also possible to mount wide sprocket packs. An important upgrade for young cyclists, who often need to use an 18 gear at the start.



### Rim Brake

The Cartesio bike is also intended for the use of traditional rim brakes, to also cover a very young consumer target.

# Cartesio Rim. For the champions of tomorrow

Your first step towards the Olympus of cycling. Cartesio is a carbon racing bicycle with rim brakes, designed to stand out among its competitors for reactivity and performance.

## Frame

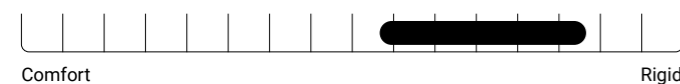

## Trim



## Frame colors available

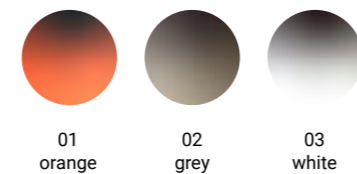

## Summing up

Use	Frame material	Braking system
Road	Carbon	Rim

## Available sizes

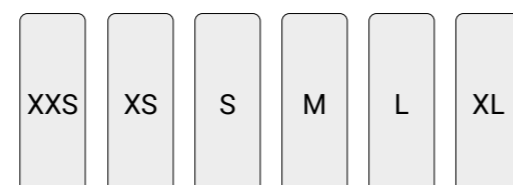

## Frame

Fork	Carbon
Headset	Oversize (1-1/8 - 1-1/2)
BB Shell	Press-Fit
Seatpost	27.2
Thru axles	✓
Flat mount	✓
Electronic groups preparation	✓

## Components

Pedal	Not included
Saddle	San Marco Monza
Seatpost	QTC Energy
Stem	QTC Alloy
Handlebar	QTC Energy
Tires	Vittoria Zaffiro Pro
Bottle cage	Not included

## Mounting options

Groupset	Shimano 105 7000 11v
Wheels	QTC Racing Alloy



02  
grey



01  
orange





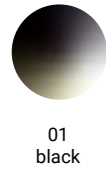

1600 g  
Frame weight

120 kg  
Weight limit

## Characteristics

Aluminum racing frame with carbon fork

Cable passage inside the frame

Entry level bike with very good performances

## What will you like?

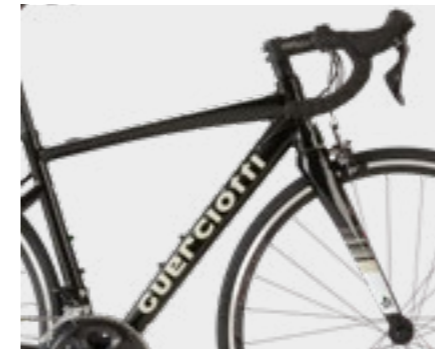

### Design

The design of the frame is of a high standard and is characterized by classic and stylish color alternatives



### Cable routing

Cable routing inside the frame to offer an excellent combination of style and functionality.



### Geometries

Geometries designed to also meet the needs of users belonging to the very young categories.

# San Siro. Your first Guerciotti

San Siro is our entry level product in Aluminum, but it features technical solutions designed to make this bike attractive to a demanding public. San Siro, the ideal bicycle to start cycling in style.

## Frame

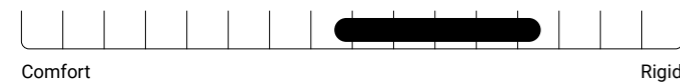

## Trim



## Frame colors available

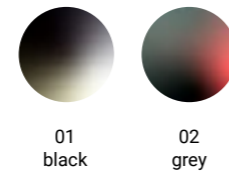

## Summing up

Use	Frame material	Braking system
Road	Aluminum	Rim

## Available sizes

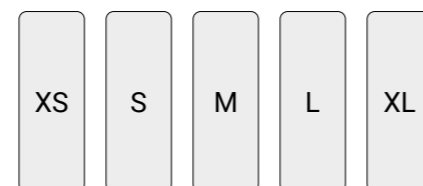

## Frame

Fork	Carbon
Headset	different thicknesses (1-1/8 - 1-1/2)
BB Shell	Press-Fit
Seatpost	27.2
Thru axles	✓
Flat mount	✓
Electronic groups preparation	✓

## Components

Pedal	Not included
Saddle	San Marco Monza
Seatpost	QTC Energy
Stem	FSA Omega
Handlebar	FSA Vero
Tires	Vittoria Zaffiro Pro
Bottle cage	Not included

## Mounting options

Groupset	Shimano Sora 9v Shimano Tiagra 4700 10v Shimano 105 7000 11v
Crankset	FSA Vero CT
Wheels	QTC Racing Alloy



02  
grey



# Gravel

Escape	116
Brera	122
Greto S	126
Greto	130

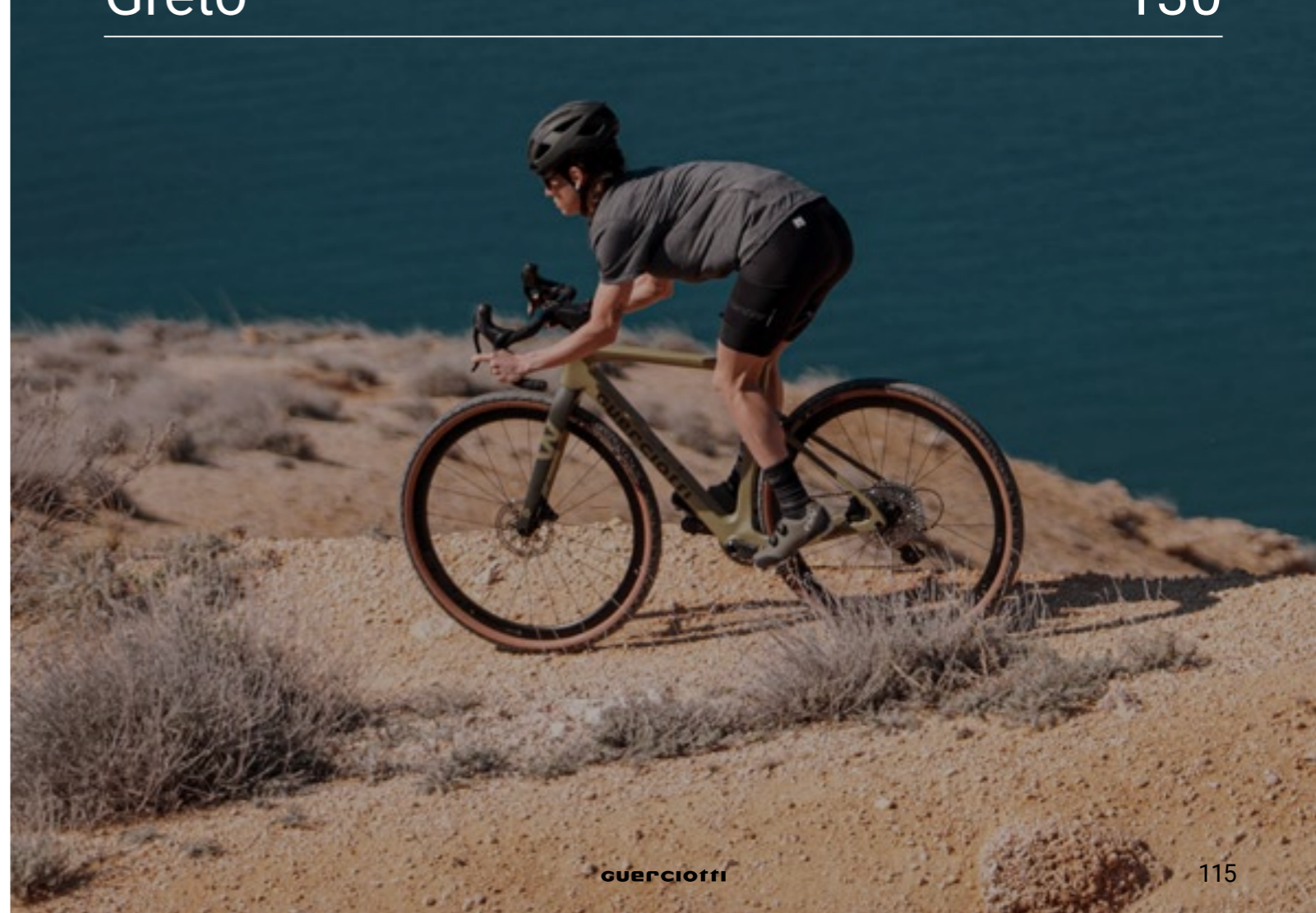

# Escape: That Gravel that chases your dream



## Cycling on the ancient Japanese imperial road

The journalist and cyclist Caterina Zanirato documented her journey on the 660-kilometer Nakasendo Road on Instagram. She was told no foreigner had ever completed it by bike.

## A journey through the history of Japan

The Nakasendo road is the ancient imperial road that connected the capital of Japan at that time, Kyoto, to the city of Edo, now Tokyo. Six hundred kilometers of hills and mountains, today passable on foot, a sort of secular Camino de Santiago. Caterina accomplished this feat on her Escape.



## Patagonia Expedition

From San Carlos De Bariloche (Argentina) to Punta Arenas (Chile), Matteo and Marine traveled the entire Carretera Austral Chilena (Ruta 7) crossing the most beautiful Argentine and Chilean national parks, such as Torres Del Paine, the eighth wonder of the world.

Mountains, glaciers, lakes, fjords, desert, sea, volcanoes and hills. Patagonia has it all.

A journey to the "end of the world".

Punta Arenas is the last mainland city on the South American continent before the South Pole.

Time  
🕒 24 days

Distance  
📏 2.461 km

Elevation gain  
⬆️ 31.960 m

kcal burned  
🔥 58.234 Kcal





1120 g  
Frame weight

120 kg  
Weight limit

## Characteristics

Very high modulus monocoque carbon fiber frame

Fork with standard inclination but designed to lower the trail

Geometries designed to obtain a rigid and reactive bike when changing direction

New dropout with UDH system for the Escape S version

Thru-axle hubs for an extremely stiff setup

## What will you like?

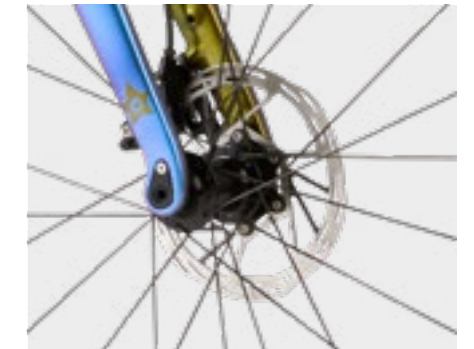

### Dropout with UDH system

For the Escape S version, the use of the new UDH system dropout guarantees greater solidity and resistance and allows the assembly of the new SRAM RED XPLR 1x13 groupset.

### Rear chassis

In the G and S versions, the frame has some modifications to accommodate tires of different widths. Up to 47 mm for the G version and 38 mm for the S version, the most racing version of the two.

### Disc brakes

Hydraulic disc brake, a solution that could not be missing in a bike designed to go fast on any surface

# Escape. The best performing hybrid

A gravel bicycle with a double soul, created to compete and satisfy the many road cyclists who are approaching the gravel movement. Elastic but at the same time extremely rigid in the relaunch phase, Escape is available in two versions. The G version with a more gravel-oriented soul and the S version for those who want greater performance even on asphalt.

## Frame



## Trim



## Frame colors available



## Summing up

Use	Frame material	Braking system
Gravel	Carbon	Disc

## Available sizes

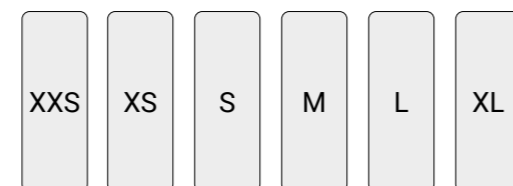

## Frame

Fork	Carbon
Headset	Oversize (1-1/2 - 1-1/2)
BB Shell	Press-Fit
Seatpost	Escape
Thru axles	✓
Flat mount	✓
Electronic groups preparation	✓

## Components

Pedal	Not included
Saddle	Selle Italia SLR X-Cross
Seatpost	Escape
Stem	QTC Carbon
Handlebar	FSA Adventure
Tires	Challenge Gravel Grinder
Bottle cage	Not included

## Mounting options

Groupset	Sram Red XPLR 1x13 (only in the S version) Sram Rival XPLR 1x12 Sram Apex AXS 1x12 Shimano GRX 820 2x12 Shimano GRX 822 1x12 Campagnolo Ekar 1x13
Wheels	Ursus Orion Disc Alloy Ursus TC37 Carbon TLR



01  
light blue

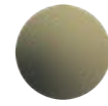

03  
green



02  
powerd



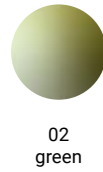

02  
green



1270 g  
Frame weight

120 kg  
Weight limit

## Characteristics

Carbon gravel frame, reinforced at the points of maximum torsion

Flared handlebar that allows the mounting of a handlebar bag

Possibility of mounting tires up to 42 mm

Latest generation braking system, with disc brakes and flat mount calipers

Hubs with thru axle, for an extremely rigid setting

Bag eyelets and space for two water bottles

## What will you like?



### Flared handlebar

A flared handlebar is mounted on the Brera. Its particular shape, now identifying the gravel segment, facilitates control of the bike on gravel or dirt. A choice oriented towards comfort and safety, which also allows the mounting of a handlebar bag.



### Bikepacking eyelets

Brera offers you a wide possibility of customization. The frame of this bicycle is in fact designed to transform into a perfect travel companion. Thanks to the special eyelets, it can accommodate your bags and up to two water bottles.



### Wide tyres

The design of the fork allows the mounting of wide rims with "oversize" tires (up to 42 mm). This solution, derived from cyclocross, gives stability to the bicycle.

## Brera. Off-road icon

The speed of the racing bike, the handling of the MTB. With Brera you will experience a different way of pedaling. Straddling asphalt and off-road, its less extreme driving position will give you ideal comfort to allow you to discover new corners of your territory. With style.

### Frame

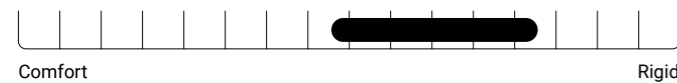

### Trim

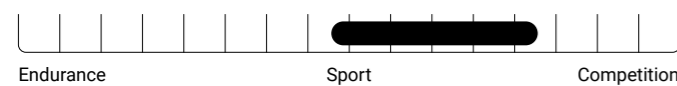

### Frame colors available

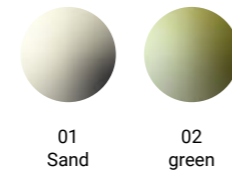

01  
Sand

02  
green

## Summing up

Use	Frame material	braking system
Gravel	Carbon	Disc

### Available sizes

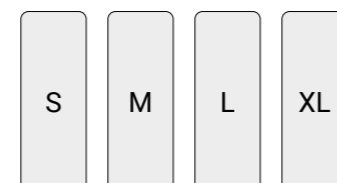

## Frame

Fork	Carbon
Headset	Oversize (1-1/8 - 1-1/2)
BB Shell	Press-Fit
Seatpost	27.2
Thru axles	✓
Flat mount	✓
Electronic groups preparation	✓

## Components

Pedals	Not included
Saddle	San Marco Monza
Seatpost	QTC Raizer
Stem	FSA V Drive
Handlebar	FSA Adventure
Tires	Challenge Gravel Grinder Comp
Bottle cage	Not included

## Mounting options

Groupset	Shimano GRX 400 2x10 Shimano GRX 600 1x11 Shimano GRX 600 2x11
Crankset	Shimano FC RX600 (for groups GRX600 2x11 and GRX400 2x10) QTC Revolution 1x11 (for group GRX600 1x11)
Wheels	QTC Syntax Alloy



01  
sabbia

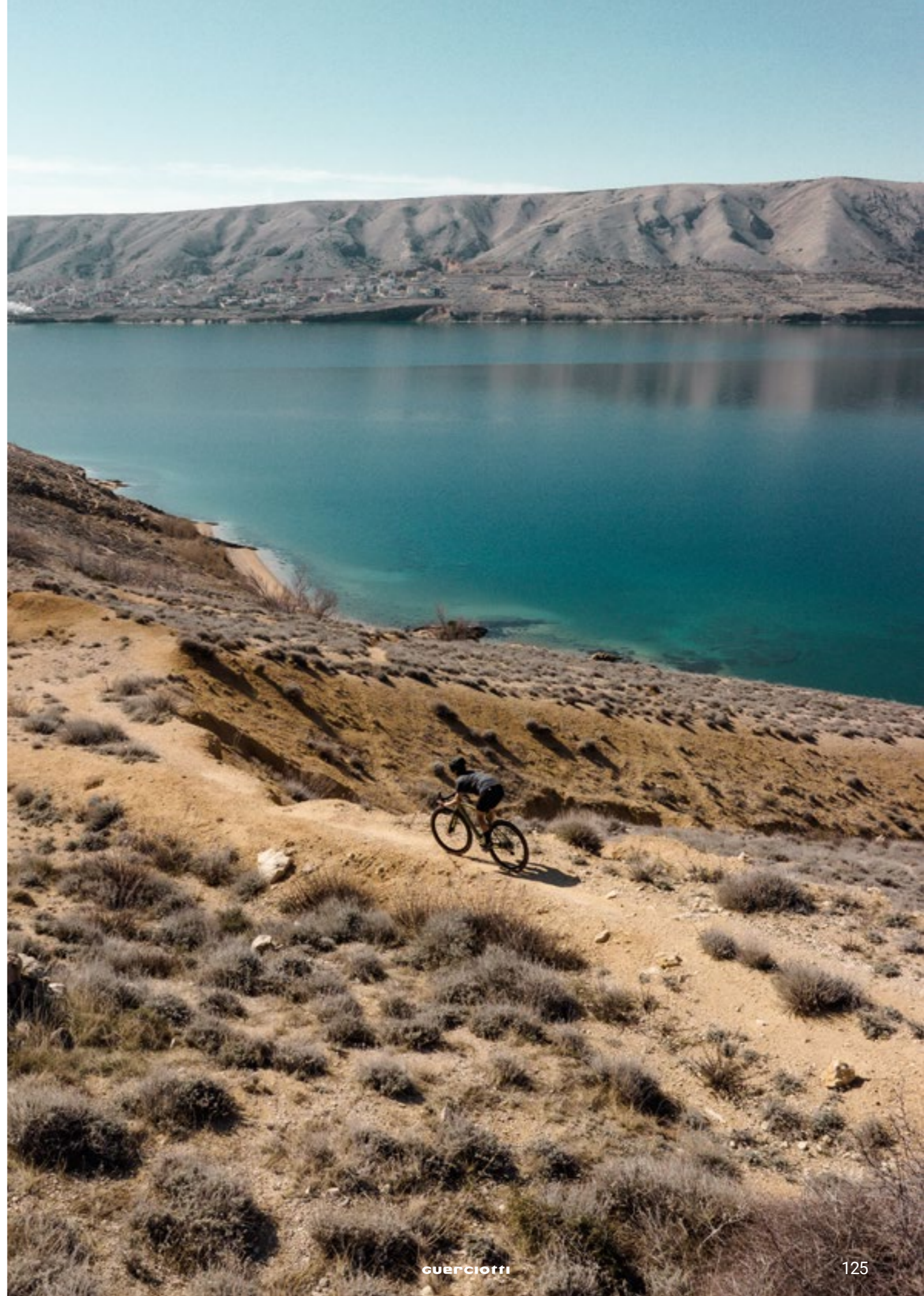

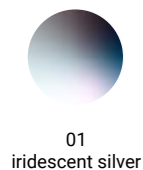

1490 g  
Frame weight

120 kg  
Weight limit

## Characteristics

Aluminum gravel frame with carbon fork

Possibility of mounting the QTC Aluminium integrated handlebar

Possibility of mounting tires up to 47 mm

Geometry redesigned to meet even better the gravelist's needs

New design of the lowered horizontal rear stay to improve performance

Bag eyelets and space for two water bottles

## What will you like?



### Comfort geometry

For the Greto S the geometries have been revised to allow for a more comfortable position and offer the possibility of longer pedaling.



### Cable integration

Adoption of integrated cables, to offer a bike that is aesthetically attractive and closer to the top of the range in terms of technical solutions adopted.



### Integrated handlebar

Possibility of mounting the new QTC integrated handlebar to offer the perfect combination of technique and style.

# Greto S. Your latest generation gravel bike

Greto S represents the evolution of Greto, the Guerciotti aluminum model intended for gravel, among the most popular on the market. Greto S presents itself as a product comparable to high-end bikes thanks to a more attractive proposal both in terms of style and technical solutions adopted.

## Frame



## Trim

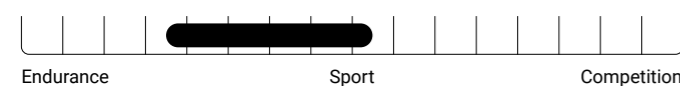

## Frame colors available

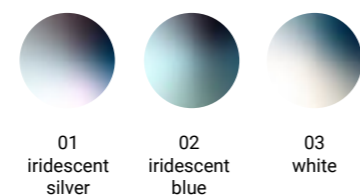

## Summing up

Use	Frame material	Braking system
Gravel	Aluminum	Disc

## Available sizes



## Frame

Fork	Carbon
Headset	Oversize (1-1/8 - 1-1/2)
BB Shell	BSA
Seatpost	27.2
Thru axles	✓
Flat mount	✓
Electronic groups preparation	✓

## Components

Pedals	Not included
Saddle	San Marco Monza
Seatpost	QTC Raizer
Stem	QTC Alloy
Handlebar	FSA Adventure
Tires	Challenge Gravel Grinder Comp
Bottle cage	Not included

## Mounting options

Groupset	Shimano GRX 400 2x10 Shimano GRX 600 1x11 Shimano GRX 600 2x11 SRAM Apex AXS 1x12
Crankset	Shimano FC RX600 (for groups GRX600 2x11 and GRX400 2x10) QTC Revolution 1x11 (for group GRX600 1x11)
Wheels	QTC Syntax Alloy Ursus Orion Disc Alloy





03  
white



02  
iridescent  
blue



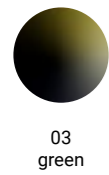

03  
green

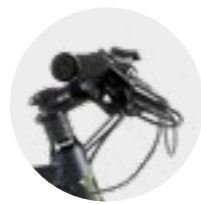

Available with  
Flat Handlebar

1490 g  
Frame weight

120 kg  
Weight limit

## Greto. Our all-rounder gravel

From the urban jungle to complete immersion in Nature, and back. In Greto you will find the same technical solutions as a top of the range, with all the concreteness of a very light aluminium frame with an excellent quality/price ratio.

### Frame



### Trim

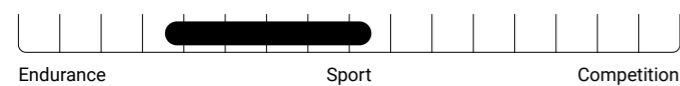

### Frame colors available

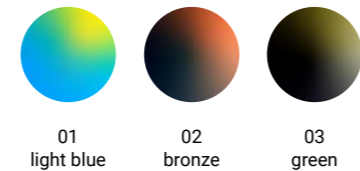

### Summing up

Use	Frame Material	Braking system
Gravel	Aluminum	Disc

### Available sizes

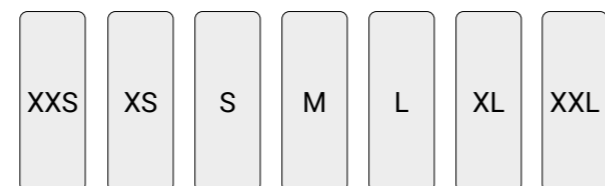

## Characteristics

Aluminum gravel frame with carbon fork

Flared handlebar that allows the mounting of a handlebar bag

Possibility of mounting tires up to 40 mm

Latest generation braking system, with disc brakes and flat mount calipers

Hubs with thru axle, for an extremely rigid setting

Bag eyelets and space for two water bottles

## What will you like?



### Bikepacking eyelets

Greto offers you a wide range of customization options. The frame of this bicycle is in fact designed to transform into a perfect travel companion. Thanks to the special eyelets, also positioned on the top tube, it can accommodate your bags and up to two water bottles.



### Disk brakes

Disc brakes provide an absolutely effective braking experience. In gravel, where you may have to deal with muddy and wet conditions, this is crucial. The hydraulic cables are completely integrated inside the frame.

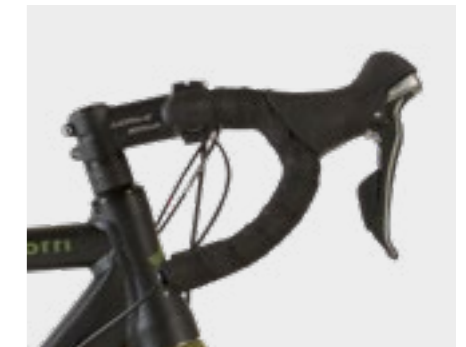

### Flared handlebar

A flared handlebar is mounted on Greto. Its particular shape, now identifying the gravel segment, makes it easier to control the bike on gravel or dirt. A choice oriented towards comfort and safety, which also allows the mounting of a handlebar bag.

## Frame

Fork	Carbon
Headset	Oversize (1-1/8 - 1-1/2)
BB Shell	BSA
Seatpost	27.2
Thru axles	✓
Flat mount	✓
Electronic groups preparation	✓

## Componentistica

Pedals	Not included
Saddle	San Marco Monza
Seatpost	QTC Raizer
Stem	FSA V-Drive
Tires	Challenge Gravel Grinder Comp
Bottle cage	Not included

## Opzioni di montaggio

Groupset	Shimano GRX400 2x10 Shimano GRX600 1x11 Shimano GRX600 2x11 SRAM NX 1x11*
Crankset	Shimano FC RX600 (for groups GRX600 2x11 e GRX400 2x10) QTC Revolution 1x11 (for group GRX600 1x11)
Handlebar	FSA Adventure QTC Flat Touring*
Wheels	QTC Syntax Alloy

\*only for Touring version



02  
bronze



Available with  
Flat Handlebar



01  
light blue



Available with  
Flat Handlebar



# Cyclocross



Guerciotti: cross soul	136
Eureka CXS	138
Silvelle	142



# Passion that generates quality

Paolo and Alessandro Guerciotti, president and team manager respectively, are always close to our boys and girls. This visceral relationship with the most successful team in Italy is the real lever behind the development of Guerciotti cyclocross bicycles, recognized today as the best on the market.



## Guerciotti: cross soul

The Guerciotti family, with the team that bears its name, has made the history of Italian cyclocross. The Guerciotti stars shone 81 times, winning titles in every corner of Europe.



## Forge of champions



There are numerous absolute champions of this discipline who have raced and won on Guerciotti bikes. Roland Liboton was with us from '83 to '87, winning two World titles. Vito Di Tano became world champion in '79 and '86. Followed by the successes of Daniele Pontoni, between '95 and '97 who brought us a World Cup and brought the world title back to the team. Among the women we remember a young Sanne Cant at her debut and Alice Arzuffi. And then Djernis, Fontana, Dorigoni and our captain Gioele Bertolini.



1120 g  
Frame weight

120 kg  
Weight

### Characteristics

Frame in very high modulus monocoque carbon fiber, cold-worked in full EPS resin

Cable passage inside the frame

Racing geometries to guarantee reactivity in changes of direction

Latest generation braking system, with disc brakes and flat mount calipers

Hubs with thru axle, to further increase rigidity

### What will you like?



#### Frame

Frame developed to better discharge mud, thanks to the greater space between the column and the rear wheel.



#### Dropout with UDH system

The new UDH dropout features greater strength and resistance and allows for the assembly of the new SRAM RED XPLR 1x13 groupset.



#### Integrated handlebar option

Also available with QTC integrated carbon handlebar, for an elegant but at the same time aggressive cockpit

## Eureka CXS. Mud ruler

To continue the winning tradition, Guerciotti offers a top of the range with an extremely racing vocation. Twin of Escape, Eureka CXS differs in terms of assembly aimed at competing in cross. Elastic, but at the same time rigid during the relaunch phase

### Frame



### Trim



### Frame colors available



### Summing up

Use	Frame material	Braking system
Cyclocross	Carbon	Disc

### Available sizes

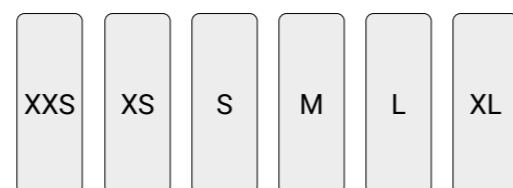

### Frame

Fork	Carbon
Headset	Oversize (1-1/2 - 1-1/2)
BB Shell	Pressfit
Seatpost	Eureka CXS
Thru axles	✓
Flat mount	✓

### Components

Pedals	Not included
Saddle	SMP VT20C
Seatpost	Eureka CXS
Stem	QTC Carbon
Handlebar	QTC Energy
Bottle cage	Not included

### Mounting options

Groupset	Shimano GRX 820 2x12 Shimano GRX 822 1x12 Sram Red XPLR 1x13 Sram Rival XPLR 1x12 Sram Apex AXS 1x12
Wheels	Ursus Orion Disc Alloy with Tires Challenge Grifo Wire 33  Ursus TS37 Carbon Tubular with Dugast tubulars



01  
White Italy





1120 g  
Frame weight

120 kg  
Weight limit

## Characteristics

Very high modulus monocoque carbon fiber frame

Cable routing integrated into the frame

New geometries designed to meet the needs of users who require smaller sizes

Latest generation braking system, with disc brakes and flat mount calipers

Hubs with thru axle, to further increase rigidity

## What will you like?



### Frame

Frame developed to better discharge mud, thanks to the greater space between the column and the rear wheel.

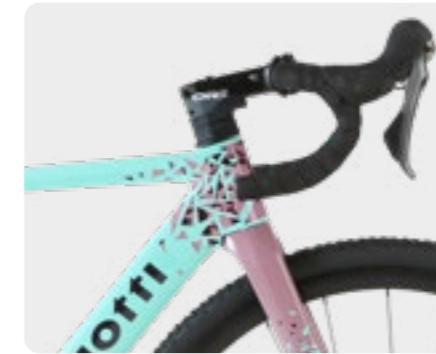

### Internal cables

Goodbye to dirt between the cables, thanks to the internal passage that starts from the handlebar. A solution that gives practicality, reliability and fantastic design to the cockpit.



### Integrated handlebar option

Possibility of mounting the aluminium integrated QTC handlebar, to completely hide the wires inside the stem and the handlebar.

## Silvelle. Mud challenge

Your first carbon cyclocross bike. The Silvelle frame is developed by the technicians of the Guerciotti team and assembled with components which ensures an excellent quality-price ratio. The offer of small sizes also represents an opportunity for both the female public and young cross riders, making it the most transversal product to start competing on muddy tracks

### Frame



### Trim

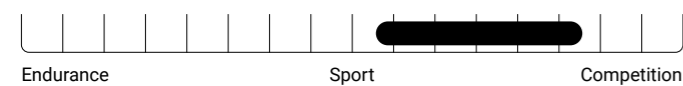

### Frame colors available

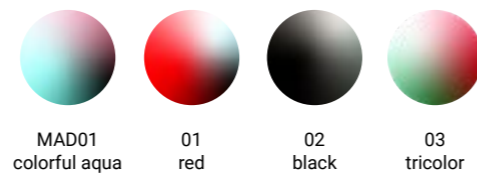

## Summing up

Use	Frame material	Braking system
Cyclocross	Carbon	Disc

### Available sizes

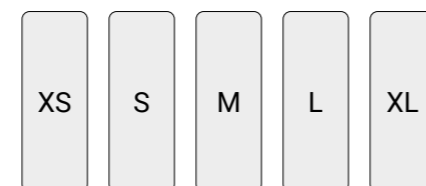

### Frame

Fork	Carbon
Headset	Oversize (1-1/2 - 1-1/2)
BB Shell	Pressfit
Seatpost	27.2
Thru axles	✓
Flat mount	✓

### Components

Pedals	Not included
Saddle	San Marco Monza
Seatpost	QTC Energy
Stem	QTC Alloy
Handlebar	QTC Energy
Bottle cage	Not included

### Mounting options

Groupset	Shimano GRX 600 1x11 Shimano GRX 812 1x11 SRAM Apex AXS 1x12
Wheels	Ursus Orion Disc Alloy with Tires Challenge Grifo Wire 33  Ursus TS37 Carbon Tubular with Dugast tubulars





01  
Red



03  
tricolor

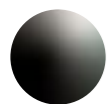

02  
black



# Milano

URBAN ELECTRIC

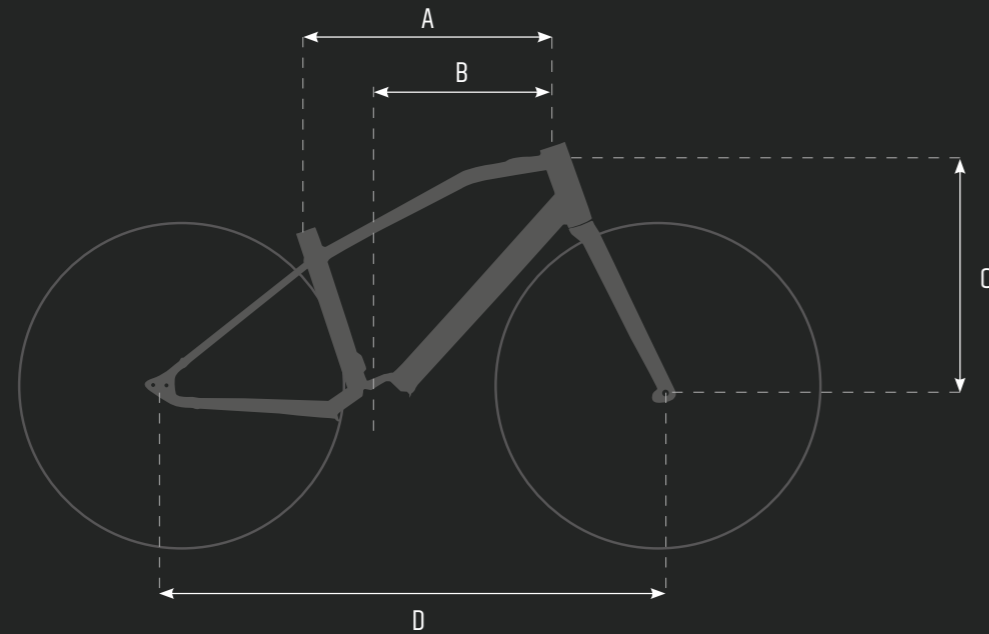

Measures	Height (cm)	A (mm)	B (mm)	C (mm)	D (mm)	E* (mm)
SLOPING GEOMETRIES MILANO FRAME (mm)						
S	160 - 168	552	384,8	547,1	1066,9	680
M	168 - 177	558	401,6	585	1096,2	680
L	177 - 186	600	408,1	608,6	1111,4	680

\*E: Handlebar width

# Navir I.ON

ELECTRIC RACE

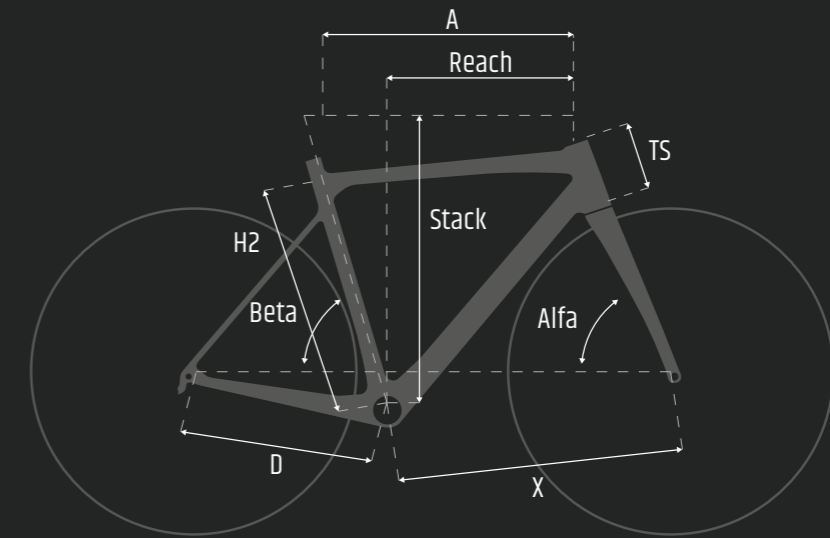

Measures	H2	A	X	D	TS	Beta	Alfa	Reach	Stack
SLOPING GEOMETRIES NAVIR I.ON FRAME (mm)									
XS	470	515	576,4	420	115	75,5°	72,25°	380	522
S	500	537	586,7	420	131	74,5°	72,5°	389,4	532,3
M	530	555	592,6	420	151	73,5°	72,75°	391,4	562,3
L	560	577	606,9	420	170	73°	73°	403,4	567,5
XL	590	600	621,3	420	190	72,76°	73,58°	418,7	583,8

## Mechanics

Engine rear	Mahle X35+
battery	248Wh, 36V Panasonic
Pinion gear change	Pinion - Gearbox C1.6 Set

## Components

Pedals	Pedals EF102 Black
Saddle	Selle Royal Vivo Unitech Sport Ergo Man
Tires	Pirelli Cycl-e DTs

## Frame

Fork	Monocoque
Headset	Oversize (1-1/8 - 1-1/2)
Seatpost	27,2
Thru axles	✓
Flat mount	✓
Electronic groups preparation	✓

## Components

Pedals	Not included
Saddle	Selle Italia Model X
Seatpost	QTC Energy
Stem	QTC Carbon
Handlebar	QTC Energy
Tires	Michelin Power Cup
Bottle cage	Not included

## Opzioni di montaggio

Groupset	Shimano 105 7020 11v Shimano 105 7170 12v di2 Shimano Ultegra 8020 11v
Wheels	Vision Team 30 AGX i23 Vision SC40 Carbon

# Sempione I.ON

ELECTRIC RACE

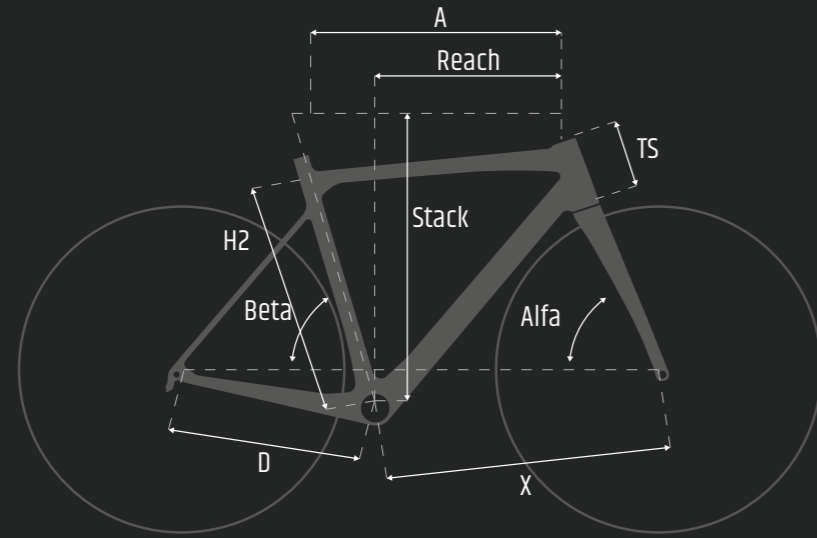

Measures	H2	A	X	D	TS	Beta	Alfa	Reach	Stack
SLOPING GEOMETRIES SEMPIONE I.ON FRAME (mm)									
XS	450	515	579	438	117	71°	74,5°	366,9	532,4
S	480	531	587	438	136	71,5°	74°	372,6	552,3
M	500	547	594	438	157	72°	73,5°	377	574
L	520	558	599	438	177	72,5°	73,5°	381,8	594,9
XL	540	574	610	438	196	72,5°	73°	386,6	613,3

# Brera I.ON

ELECTRIC GRAVEL

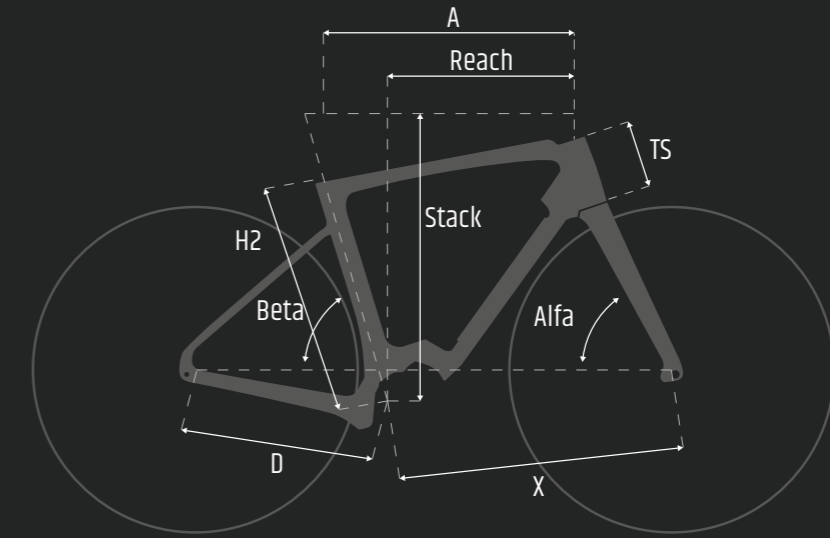

Measures	H2	A	X	D	TS	Beta	Alfa	Reach	Stack
BRERA I.ON FRAME SLOPING GEOMETRIES (mm)									
XS	490	525	596,6	445	115	74,5°	70,5°	377,2	533
S	520	535	600,6	445	135	74°	71°	379,3	556
M	540	545	602,7	445	145	73,5°	71,5°	379,8	565,2
L	560	560	605,4	445	165	73°	72°	380,2	586,1
XL	580	575	614,9	445	185	72,5°	72°	384,2	605,2

## Frame

Fork Carbon

Headset Oversize (1-1/8 - 1-1/2)

Seatpost 27,2

Thru axles ✓

Flat mount ✓

Electronic groups preparation ✓

## Components

Pedals Not included

Saddle Selle Italia X1

Seatpost QTC Energy

Stem FSA Omega

Handlebar FSA Vero

Tires Vittoria Zaffiro Pro

Bottle cage Not included

## Mounting options

Groupset Shimano 105 7020 11v  
Shimano Ultegra 8020 11v

Wheels Ursus Orion disc alloy

## Frame

Fork Carbon

Headset Oversize (1-1/2 - 1-1/2)

Seatpost Brera I.ON

Thru axles ✓

Flat mount ✓

Electronic groups preparation ✓

## Components

Pedals Not included

Saddle San Marco Monza

Seatpost Brera I.ON

Stem QTC Carbon

Tires Challenge Gravel Grinder Comp

Bottle cage Not included

## Mounting options

Groupset Shimano GRX 400 2x10  
Shimano GRX 600 1x11  
Shimano GRX 600 2x11  
SRAM Apex AXS 1x12  
SRAM NX 1x11\*

Handlebar FSA Adventure  
QTC Flat Touring\*

Wheels Ursus Orion Disc Alloy  
Ursus C37 Carbon TLR

\*only for Touring version

# Greto I.ON 630

ELECTRIC GRAVEL

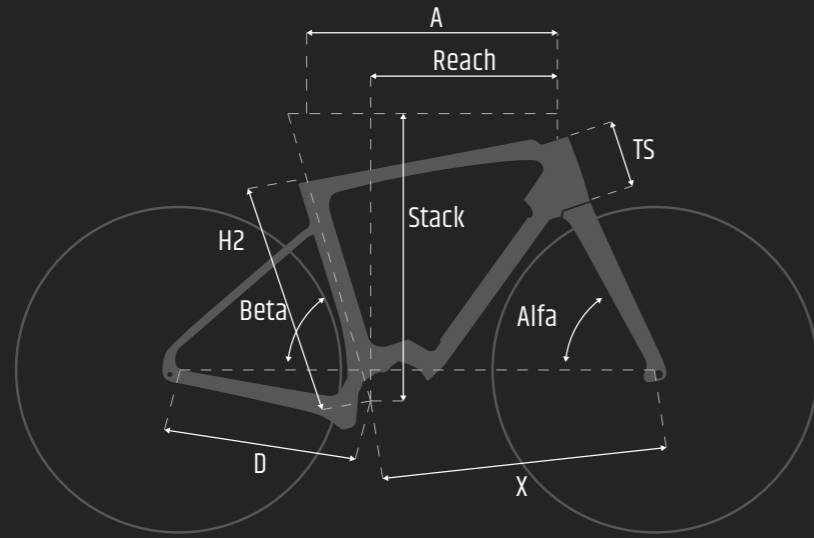

Measures	H2	A	X	D	TS	Beta	Alfa	Reach	Stack
SLOPING GEOMETRIES FRAME GRETO I.ON 630 (mm)									
XS	490	525	596,6	445	115	74,5°	70,5°	377,2	533
S	520	535	600,6	445	135	74°	71°	379,3	556
M	540	545	602,7	445	145	73,5°	71,5°	379,8	565,2
L	560	560	605,4	445	165	73°	72°	380,2	586,1
XL	580	575	614,9	445	185	72,5°	72°	384,2	605,2

# Greto I.ON

ELECTRIC GRAVEL

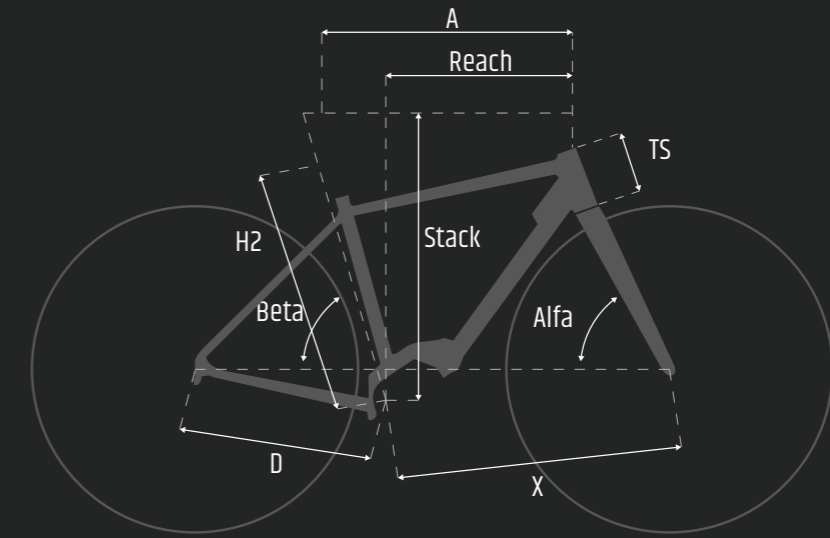

Measures	H2	A	X	D	TS	Beta	Alfa	Reach	Stack
SLOPING GEOMETRIES GRETO I.ON FRAME (mm)									
XS	460	518	592,2	454	110	74,5°	70°	366,5	539,1
S	480	534	594,7	454	125	74°	71°	374,3	557,1
M	500	550	596,3	454	140	73,5°	72°	379,7	575
L	530	566	602	454	155	73°	72,5°	385,3	591,2
XL	550	582	612,8	454	175	73°	73°	394,9	612,1

## Frame

**Fork** Carbon

**Headset** Oversize (1-1/8 - 1-1/2)

**Seatpost** QTC Razer

**Thru axles** ✓

**Flat mount** ✓

**Electronic groups preparation** ✓

## Components

**Pedals** Not included

**Saddle** San Marco Monza

**Seatpost** QTC Razer

**Stem** FSA V-drive

**Tires** Challenge Gravel Grinder Comp

**Bottle cage** Not included

## Mounting options

**Groupset** Shimano GRX 400 2x10  
Shimano GRX 600 1x11  
Shimano GRX 600 2x11  
SRAM Apex AXS 1x12  
SRAM NX 1x11\*

**Handlebar** FSA Adventure  
QTC Flat Touring\*

**Wheels** Ursus Orion Disc Alloy

\*only for Touring version

## Frame

**Fork** Carbon

**Headset** Oversize (1-1/8 - 1-1/2)

**Headset** QTC Razer

**Thru axles** ✓

**Flat mount** ✓

**Electronic groups preparation** ✓

## Components

**Pedals** Not included

**Saddle** San Marco Monza

**Seatpost** QTC Razer

**Stem** FSA V-drive

**Tires** Challenge Gravel Grinder Comp

**Bottle cage** Not included

## Mounting options

**Groupset** Shimano GRX 400 2x10  
Shimano GRX 600 1x11  
SRAM NX 1x11\*

**Handlebar** FSA Adventure  
QTC Flat Touring\*

**Wheels** Ursus Orion Disc Alloy

\*only for Touring version

# Ambrosia

ELECTRIC RACE

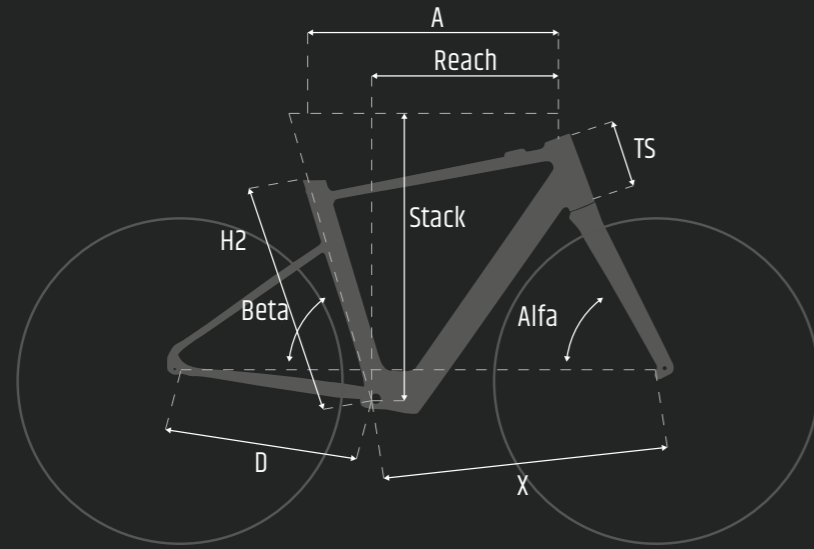

Measures	H2	A	X	D	TS	Beta	Alfa	Reach	Stack
AMBROSIA FRAME SLOPING GEOMETRIES(mm)									
S	460	528	641,3	410	140	74,5°	72°	402,6	549,5
M	500	573	653,4	410	160	74,5°	71,5°	379,7	581,8
L	540	586	656,8	410	170	74,5°	72°	395,7	602,8

# Gaia

ELECTRIC GRAVEL

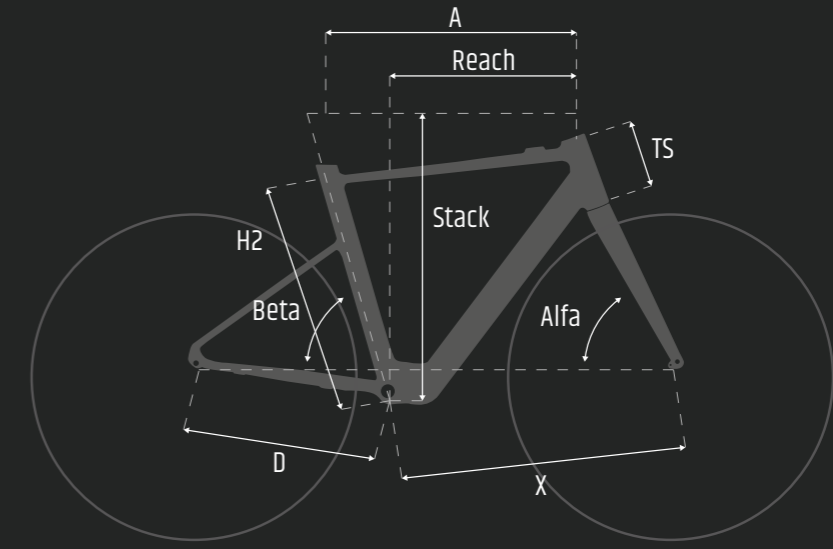

Measures	H2	A	X	D	TS	Beta	Alfa	Reach	Stack
GAIA FRAME SLOPING GEOMETRIES (mm)									
S	460	512	611	446	150	74,1°	70°	402,6	549,5
M	500	541	642	446	160	74°	70°	379,7	581,8
L	540	568	662	446	170	74,1°	70°	395,7	602,8

## Frame

Fork Carbon

Headset Oversize (1-1/2 - 1-1/2)

Seatpost QTC Energy

Thru axles ✓

Flat mount ✓

Electronic groups preparation ✓

## Components

Pedals Not included

Saddle San Marco Monza

Seatpost QTC Energy

Stem QTC Alloy

Handlebar QTC Energy

Tires Vittoria Zaffiro Pro

Bottle cage Not included

## Mounting options

Groupset Shimano 105 R7020 11V  
Shimano Ultegra 8020 11v

Wheels QTC Alloy

## Frame

Wheels Carbon

Headset Oversize (1-1/2 - 1-1/2)

Headset QTC Raizer

Thru axles ✓

Flat mount ✓

Electronic groups preparation ✓

## Components

Pedals Not included

Saddle San Marco Monza

Seatpost QTC Raizer

Stem QTC Alloy

Handlebar FSA adventure

Tires Challenge Gravel Grinder 38

Bottle cage Not included

## Mounting options

Groupset Shimano GRX 400 2x10  
Shimano GRX 600 1x11

Wheels QTC Alloy

# Eclipse S 2025

RACING BIKE

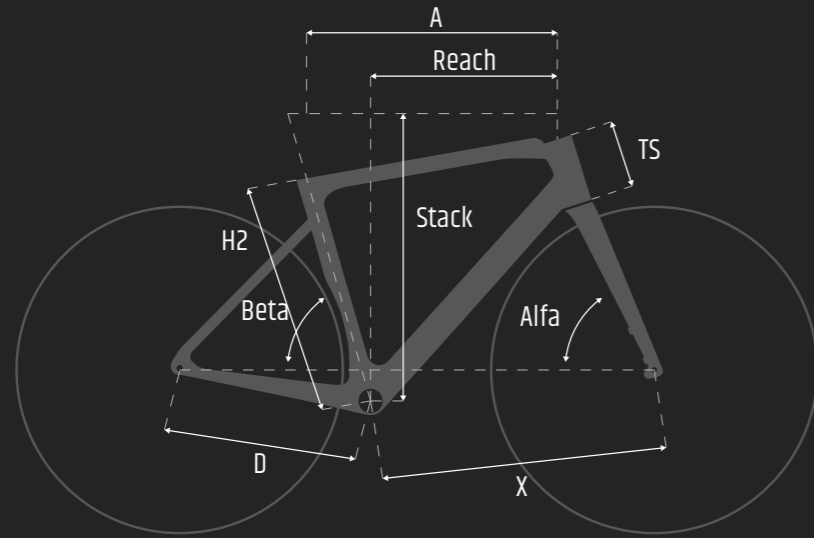

Measures	H2	A	TS	Beta	Alfa	Reach	Stack
ECLIPSE S FRAME SLOPING GEOMETRIES (mm)							
XXS	385	499	100	75°	70,5°	365	492
XS	410	515	115	75°	71°	371	508
S	445	533	130	74,5°	72°	378	525
M	480	547	145	74°	72,5°	384	546
L	515	567	170	73,5°	72,5°	395	565
XL	545	582	190	73°	73,5°	400,6	592,7

# Veloce SLR

RACING BIKE

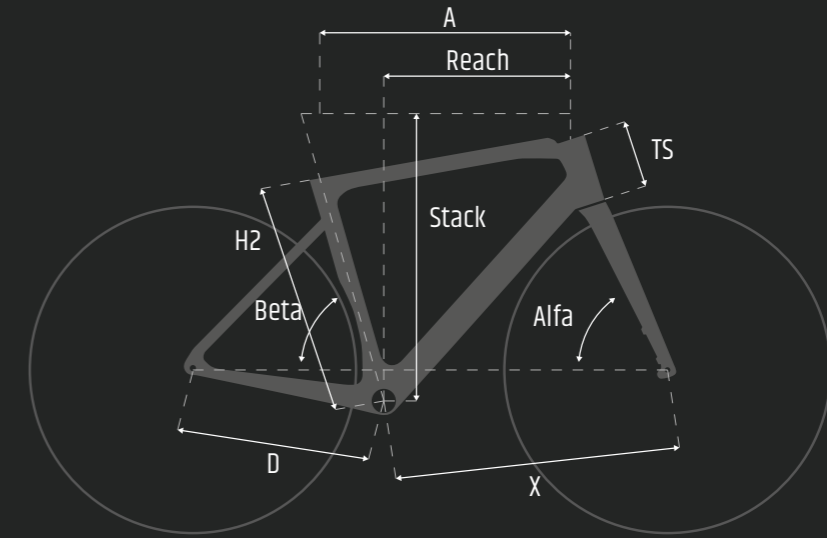

Measures	H2	A	TS	Beta	Alfa	Reach	Stack
SLOPING GEOMETRIES VELOCE SLR FRAME (mm)							
XXS	385	499	100	75°	70,5°	365	492
XS	410	515	115	75°	71°	371	508
S	445	533	130	74,5°	72°	378	525
M	480	547	145	74°	72,5°	384	546
L	515	567	170	73,5°	72,5°	395	565
XL	545	582	190	73°	73,5°	400,6	592,7

## Frame

**Fork** Carbon monocoque

**Headset** Oversize (1-1/2 - 1-1/2)

**BB Shell** Press-Fit

**Seatpost** Carbon Eclipse S

**Thru axles** ✓

**Flat mount** ✓

**Electronic groups preparationi** ✓

## Components

**Pedals** Not included

**Saddle** QTC RS Carbon

**Seatpost** Eclipse S

**Stem** QTC integrated carbon

**Handlebar** QTC integrated carbon

**Tires** Vittoria Corsa Next

**Bottle cage** Not included

## Mounting options

**Groupset** Shimano Ultegra 8170 12v di2  
Shimano Dura Ace 9270 12v di2  
SRAM Red AXS 2x12 di2

**Wheels** Vision Team 30 AGX i23  
Vision Metron 45 SL Carbon TLR  
Ursus TC47 Carbon TLR  
QTC SL Light Carbon  
QTC Hurricane Carbon

## Frame

**Fork** Carbon

**Headset** Oversize (1-1/8 - 1-1/2)

**BB Shell** T47 BSA

**Seatpost** Carbon Veloce SRL

**Thru axles** ✓

**Flat mount** ✓

**Electronic groups preparationi** ✓

## Components

**Pedals** Not included

**Saddle** Selle Italia SLR Boost Manganese

**Seatpost** Veloce SLR

**Stem** QTC Carbon

**Handlebar** QTC Energy

**Tires** Michelin Power Cup

**Bottle cage** Not included

## Mounting options

**Groupset** Shimano Ultegra 8170 12v di2  
Shimano Dura Ace 9270 12v di2  
SRAM Red AXS 2x12 di2

**Wheels** Vision Team 30 AGX i23  
Vision SC55 Carbon TLR  
Vision SC40 Carbon TLR  
Ursus TC47 Carbon TLR

# Veloce S

RACING BIKE

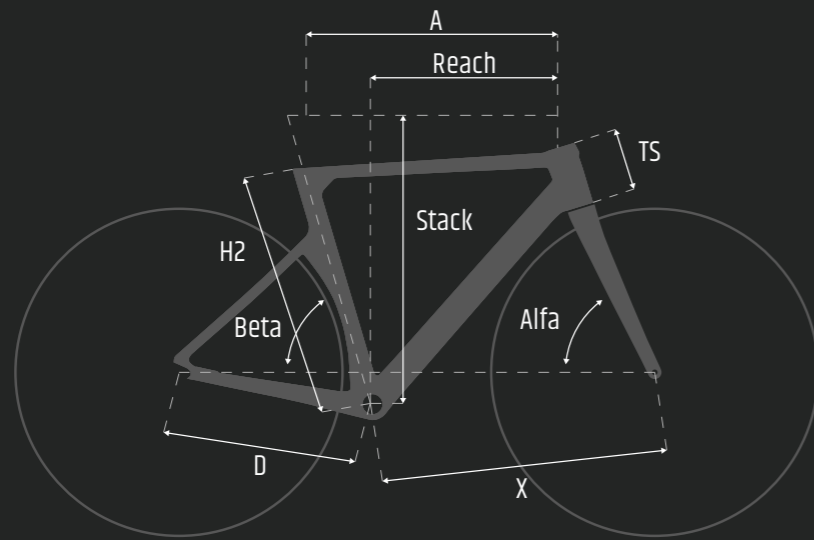

Measures	H2	A	TS	Beta	Alfa	Reach	Stack
VELOCE S FRAME GEOMETRIES(mm)							
XS	450	505	110	73,5°	71°	356	507
S	480	532	120	73,5°	72,5°	370	521
M	510	550	135	73,5°	72,8°	392	533
L	540	570	150	73°	72°	395	553
XL	570	590	170	72°	73,5°	403	573,5

# Italo

RACING BIKE

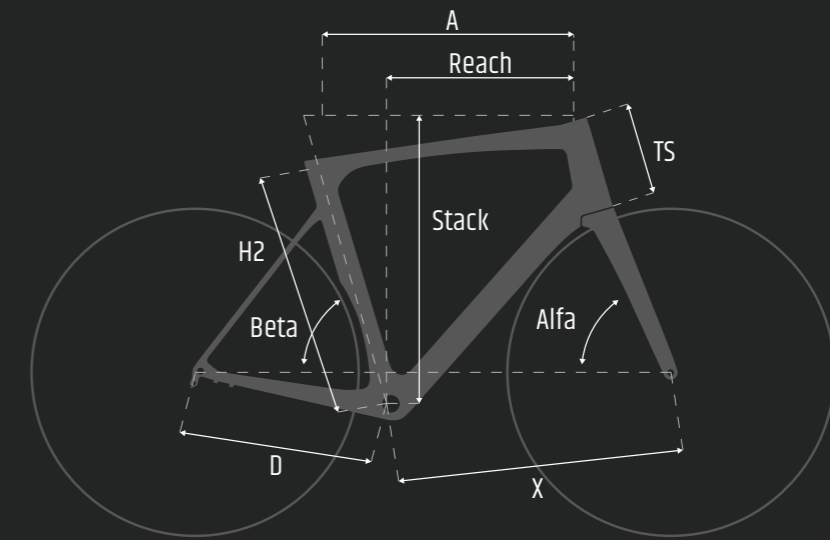

Measures	H2	A	TS	Beta	Alfa	Reach	Stack
SLOPING GEOMETRIES ITALO DISC FRAME (mm)							
XXS	420	500	110	75°	71°	364	508
XS	450	515	130	75°	71,5°	373	528
S	480	536	150	74°	72,5°	378	550
M	510	548	170	73,5°	73°	378	571
L	540	565	195	73,25°	73,5°	385	596
XL	570	587	220	73°	73,5°	397	620

## Frame

Fork Carbon

Headset Oversize (1-1/2 - 1-1/2)

BB Shell Press-Fit

Seatpost Carbon Veloce S

Thru axles ✓

Flat mount ✓

Electronic groups preparationi ✓

## Components

Pedals Not included

Saddle Selle Italia Model X

Seatpost Veloce S

Stem QTC carbon

Handlebar QTC Energy

Tires Michelin Power Cup

Bottle cage Not included

## Mounting options

Groupset Shimano 105 7120 12v  
Shimano 105 7170 12v di2  
Shimano Ultegra 8020 11v  
Shimano Ultegra 8170 12v di2

Wheels Vision Team 30 AGX i23  
Vision SC55 carbon TLR  
Vision SC40 carbon TLR  
Ursus TC47 carbon TLR

## Frame

Fork Carbon

Headset Oversize (1-1/2 - 1-1/2)

BB Shell Press-Fit

Seatpost Carbon Italo Disc

Thru axles ✓

Flat mount ✓

Electronic groups preparation ✓

## Components

Pedals Not included

Saddle Selle Italia Model X

Seatpost Italo Disc

Stem QTC carbon

Handlebar QTC Energy

Tires Vittoria Zaffiro Pro

Bottle cage Not included

## Mounting options

Groupset Shimano 105 7120 12v  
Shimano 105 7170 12v di2  
Shimano Ultegra 8020 11v

Wheels Vision Team 30 AGX i23  
Vision SC40 Carbon TLR  
QTC Syntax

# Cartesio disc

RACING BIKE

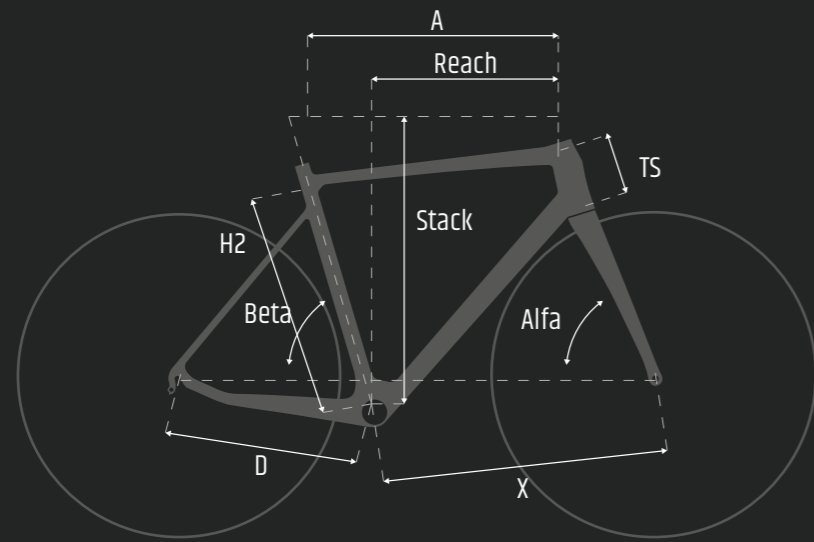

Measures	H2	A	X	D	TS	Beta	Alfa	Reach	Stack
SLOPING GEOMETRIES CARTESIO DISC FRAME(mm)									
XXS	385	499	574,4	405	100	75°	70,5°	366	498
XS	410	515	587,4	405	115	75°	71°	378	514
S	445	533	588	405	130	74,5°	72°	386	533
M	500	545	593	405	150	73,5°	73°	387	546
L	515	567	607,5	410	170	73,5°	72,5°	398	571
XL	545	582	607	410	190	73°	73,5°	400,7	593

# Cartesio Rim

RACING BIKE

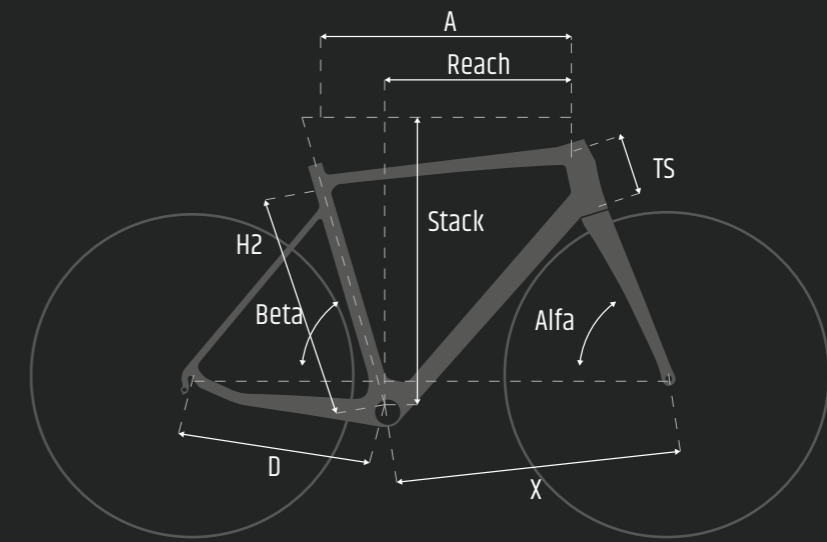

Measures	H2	A	X	D	TS	Beta	Alfa	Reach	Stack
CARTESIO RIM SLOPING FRAME GEOMETRIES(mm)									
XXS	385	499	574,4	405	100	75°	70,5°	366	498
XS	410	515	587,4	405	115	75°	71°	378	514
S	445	533	588	405	130	74,5°	72°	386	533
M	500	545	593	405	150	73,5°	73°	387	546
L	515	567	607,5	410	170	73,5°	72,5°	398	571
XL	545	582	607	410	190	73°	73,5°	400,7	593

## Frame

Fork Carbon

Headset Oversize (1-1/2 - 1-1/2)

BB Shell Press-Fit

Seatpost 27.2

Thru axles ✓

Flat mount ✓

Electronic groups preparationi ✓

## Components

Pedals Not included

Saddle San Marco Monza

Seatpost QTC Energy

Stem QTC Alloy

Handlebar QTC Energy

Handlebar Vittoria Zaffiro Pro

Bottle cage Not included

## Mounting options

Groupset Shimano 105 7120 12v  
Shimano 105 7170 12v di2  
Shimano Ultegra 8020 11v

Wheels Vision Team 30 AGX i23  
Vision SC40 Carbon TLR  
QTC Syntax

## Frame

Fork Carbon

Headset Oversize (1-1/8 - 1-1/2)

BB Shell Press-Fit

Seatpost 27.2

Thru axles ✓

Flat mount ✓

Electronic groups preparationi ✓

## Components

Pedals Not included

Saddle San Marco Monza

Seatpost QTC Energy

Stem QTC Alloy

Handlebar QTC Energy

Tires Vittoria Zaffiro Pro

Bottle cage Not included

## Mounting options

Groupset Shimano 105 7000 11v

Wheels QTC Racing Alloy



# San Siro

RACING BIKE

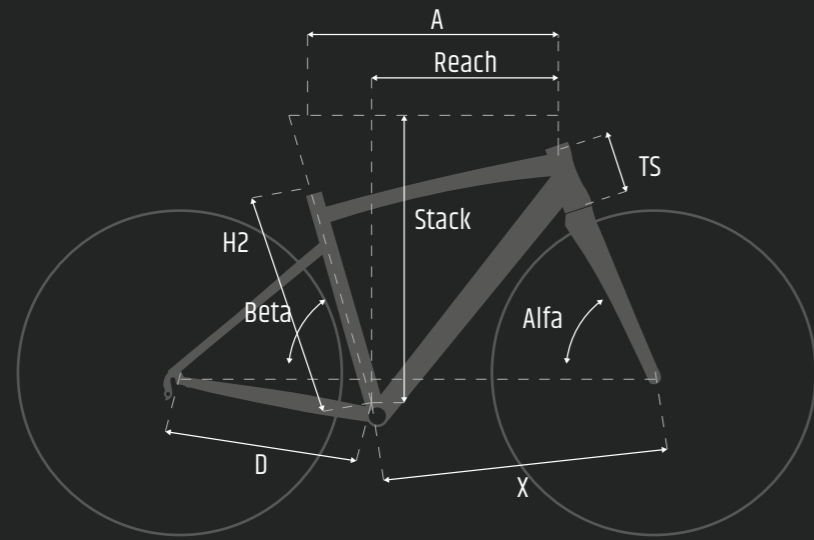

Measures	H2	A	X	D	TS	Beta	Alfa	Reach	Stack
SLOPING GEOMETRIES SAN SIRO FRAME (mm)									
XS	450	500	556,1	405	130	74°	71°	349,1	526,4
S	480	527,3	574,3	405	130	74°	72°	375,4	529,9
M	510	548	581	405	145	73,5°	73°	385,8	547,5
L	540	568,2	591	405	175	73°	73,5°	391,5	577,9
XL	570	588,3	604,9	405	205	72,5°	73,5°	397	606,7

# Escape

GRAVEL BIKE

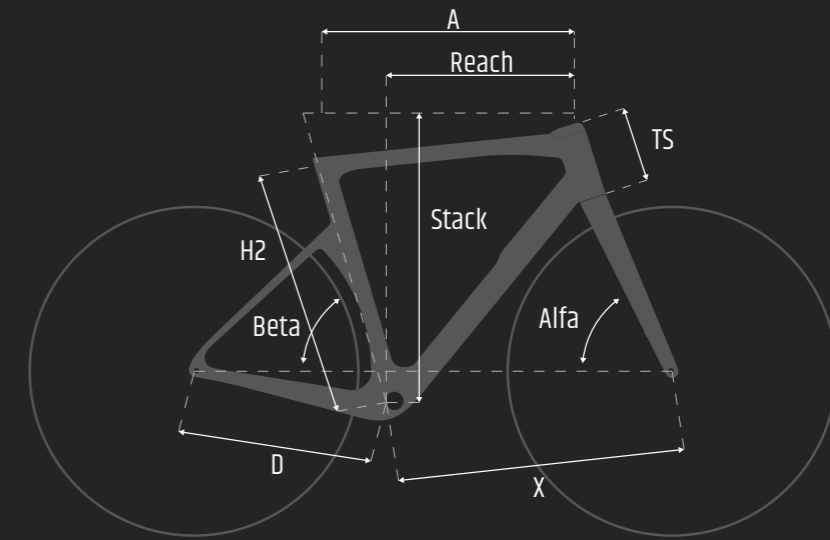

Measures	H2	A	X	D*	TS	Beta	Alfa	Reach	Stack
ESCAPE FRAME SLOPING GEOMETRIES (mm)									
XXS	440	490	572,5	425	90	75,5°	70,5°	326,6	511,8
XS	490	510	579,6	425	110	75°	71°	376,8	535,2
S	520	534,7	590,7	425	130	74°	71,5°	376	553,3
M	540	545	591,3	425	140	73,5°	72°	377,8	564,5
L	560	560	601,2	425	160	73°	72°	381,6	583,5
XL	580	575	616,5	425	180	73°	72°	390,8	602,5

\*435  
per ESCAPE G

## Frame

Fork Carbon

Headset Oversize (1-1/8 - 1-1/2)

BB Shell Press-Fit

Seatpost 27.2

Thru axles ✓

Flat mount ✓

Electronic groups preparation ✓

## Components

Pedal Not included

Saddle San Marco Monza

Seatpost QTC Energy

Stem FSA Omega

Handlebar FSA Vero

Tires Vittoria Zaffiro Pro

Bottle cage Not included

## Mounting options

Groupset Shimano Sora 9v  
Shimano Tiagra 4700 10v  
Shimano 105 7000 11v

Crankset FSA Vero CT

Wheels QTC Racing Alloy

## Frame

Fork Carbon

Headset Oversize (1-1/2 - 1-1/2)

BB Shell Press-Fit

Seatpost Escape

Thru axles ✓

Flat mount ✓

Electronic groups preparation ✓

## Components

Pedal Not included

Saddle Selle Italia SLR X-Cross

Seatpost Escape

Stem QTC Carbon

Handlebar FSA Adventure

Tires Challenge Gravel Grinder

Bottle cage Not included

## Mounting options

Groupset Sram Red XPLR 1x13 (only in the S version)  
Sram Rival XPLR 1x12  
Sram Apex AXS 1x12  
Shimano GRX 820 2x12  
Shimano GRX 822 1x12  
Campagnolo Ekar 1x13

Wheels Ursus Orion Disc Alloy  
Ursus TC37 Carbon TLR

# Brera

GRAVEL BIKE

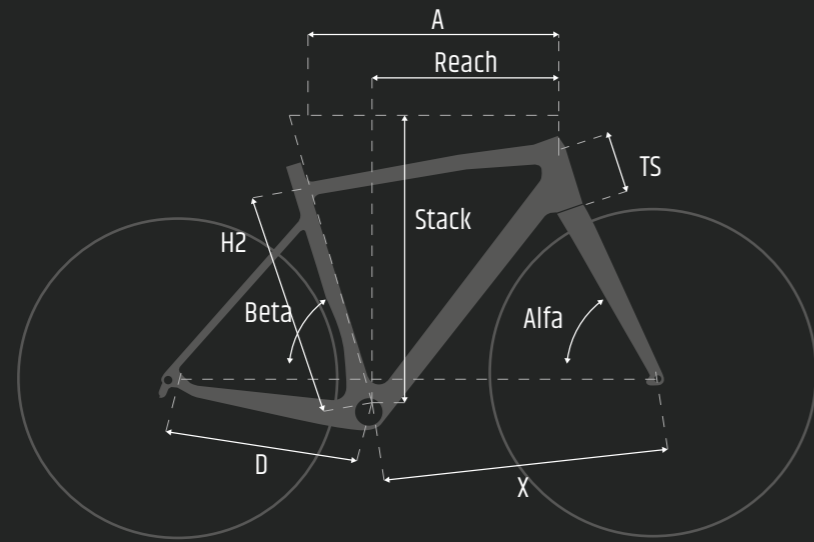

Measures	H2	A	X	D	TS	Beta	Alfa	Reach	Stack
INCLINED GEOMETRIES BRERA FRAME(mm)									
S	520	535	600,6	435	140	74°	71°	375,5	556
M	540	545	600,7	435	150	73,6°	71,5°	376,7	568
L	560	560	605,8	435	170	73°	72°	380	589
XL	580	575	605,7	435	190	72,5°	72°	384	606

# Greto S

GRAVEL BIKE

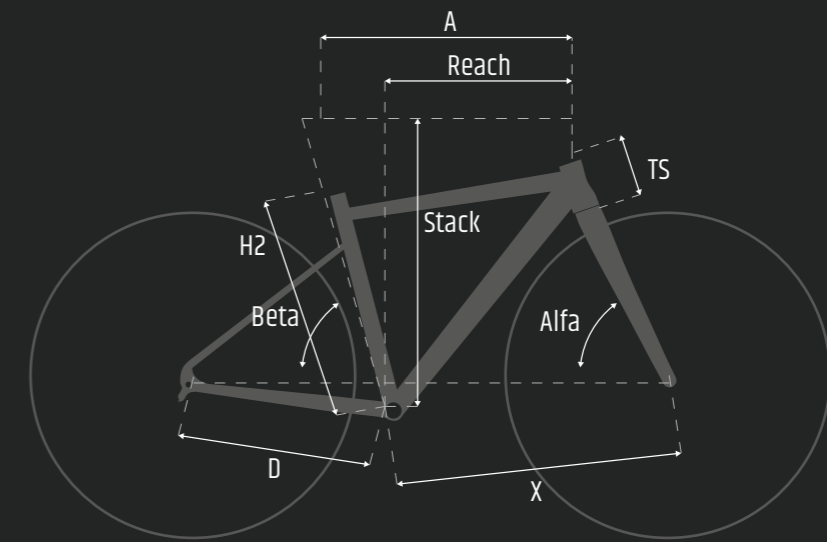

Measures	H2	A	X	D	TS	Beta	Alfa	Reach	Stack
SLOPING GEOMETRIES GRETO S FRAME (mm)									
XXS	460	495	575,1	430	100	75,5°	70,5°	374	528
XS	480	510	575,1	430	110	74,7°	70,5°	377	542
S	500	535	601,4	430	133	74°	70,5°	380	559
M	520	550	602,6	430	155	73,5°	71°	386	584
L	550	570	603,2	430	173	72,5°	71,5°	392	611
XL	580	585	608,4	430	185	72,5°	72°	399	636

## Frame

Fork Carbon

Headset Oversize (1-1/8 - 1-1/2)

BB Shell Press-Fit

Seatpost 27.2

Thru axles ✓

Flat mount ✓

Electronic groups preparation ✓

## Components

Pedals Not included

Saddle San Marco Monza

Seatpost QTC Raizer

Stem FSA V Drive

Handlebar FSA Adventure

Tires Challenge Gravel Grinder Comp

Bottle cage Not included

## Mounting options

Groupset Shimano GRX 400 2x10  
Shimano GRX 600 1x11  
Shimano GRX 600 2x11

Crankset Shimano FC RX600 (for groups GRX600 2x11 and GRX400 2x10)  
QTC Revolution 1x11 (for group GRX600 1x11)

Wheels QTC Syntax Alloy

## Frame

Fork Carbon

Headset Oversize (1-1/8 - 1-1/2)

BB Shell BSA

Seatpost 27.2

Thru axles ✓

Flat mount ✓

Electronic groups preparation ✓

## Components

Pedals Not included

Saddle San Marco Monza

Seatpost QTC Raizer

Stem QTC Alloy

Handlebar FSA Adventure

Tires Challenge Gravel Grinder Comp

Bottle cage Not included

## Mounting options

Groupset Shimano GRX 400 2x10  
Shimano GRX 600 1x11  
Shimano GRX 600 2x11  
SRAM Apex AXS 1x12

Crankset Shimano FC RX600 (for groups GRX600 2x11 and GRX400 2x10)  
QTC Revolution 1x11 (for group GRX600 1x11)

Wheels QTC Syntax Alloy  
Ursus Orion Disc Alloy

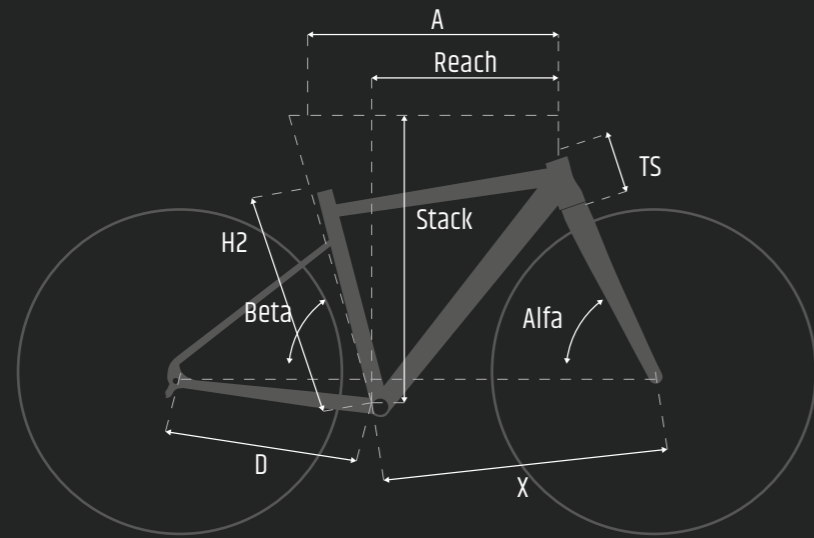

Measures	H2	A	X	D	TS	Beta	Alfa	Reach	Stack
INCLINED GEOMETRIES GRETO FRAME (mm)									
XXS	460	495	575,1	425	100	75,5°	70,5°	363,3	509,3
XS	480	510	575,1	425	100	75,5°	70,5°	378,3	509,3
S	500	525	601,4	425	115	75°	70,5°	384,7	523,4
M	520	535,1	602,6	425	125	74,5°	71°	386,8	534,7
L	540	545	603,2	425	135	74°	71,5°	388,4	546,1
XL	560	560	608,4	425	145	73,5°	72°	394,9	557,4
XXL	580	580	623	425	175	73°	72,5°	399	636

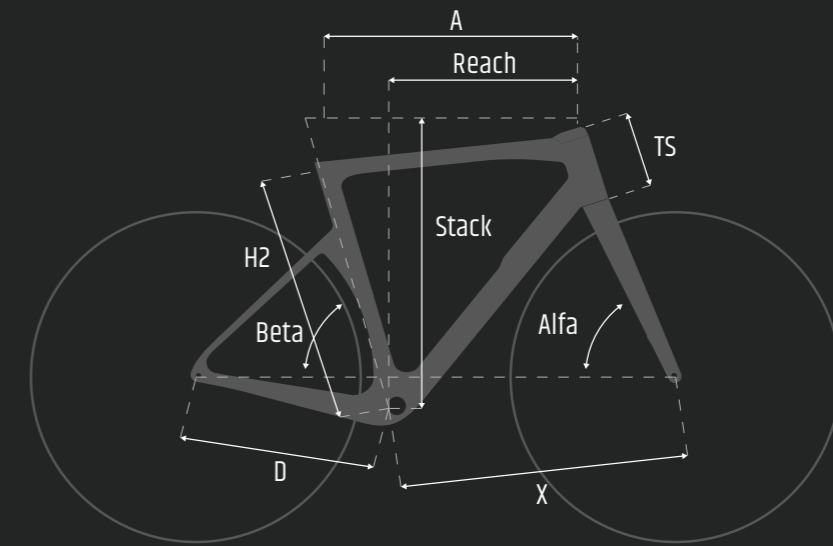

Measures	H2	A	X	D	TS	Beta	Alfa	Reach	Stack
EUREKA CXS FRAME INCLINED GEOMETRIES(mm)									
XXS	440	490	572,5	425	90	75,5°	70,5°	326,6	511,8
XS	490	510	579,6	425	110	75°	71°	376,8	535,2
S	520	534,7	590,7	425	130	74°	71,5°	376	553,3
M	540	545	591,3	425	140	73,5°	72°	377,8	564,5
L	560	560	601,2	425	160	73°	72°	381,6	583,5
XL	580	575	616,5	425	180	73°	72°	390,8	602,5

## Frame

Fork Carbon

Headset Oversize (1-1/8 - 1-1/2)

BB Shell BSA

Seatpost 27.2

Thru axles ✓

Flat mount ✓

Electronic groups preparation ✓

## Components

Pedals Not included

Saddle San Marco Monza

Seatpost QTC Raizer

Stem FSA V-Drive

Tires Challenge Gravel Grinder Comp

Bottle cage Not included

## Mounting options

Groupset Shimano GRX400 2x10  
Shimano GRX600 1x11  
Shimano GRX600 2x11  
SRAM NX 1x11\*

Crankset Shimano FC RX600 (for groups GRX600 2x11 e GRX400 2x10)  
QTC Revolution 1x11 (for group GRX600 1x11)

Handlebar FSA Adventure  
QTC Flat Touring\*

Wheels QTC Syntax Alloy

\*only for Touring version

## Frame

Fork Carbon

Headset Oversize (1-1/2 - 1-1/2)

BB Shell Pressfit

Seatpost Eureka CXS

Thru axles ✓

Flat mount ✓

## Components

Pedals Not included

Saddle SMP VT20C

Seatpost Eureka CXS

Stem QTC Carbon

Handlebar QTC Energy

Bottle cage Not included

## Mounting options

Groupset Shimano GRX 820 2x12  
Shimano GRX 822 1x12  
Sram Red XPLR 1x13  
Sram Rival XPLR 1x12  
Sram Apex AXS 1x12

Wheels Ursus Orion Disc Alloy with Tires Challenge Grifo Wire 33

Ursus TS37 Carbon Tubular with Dugast tubulars

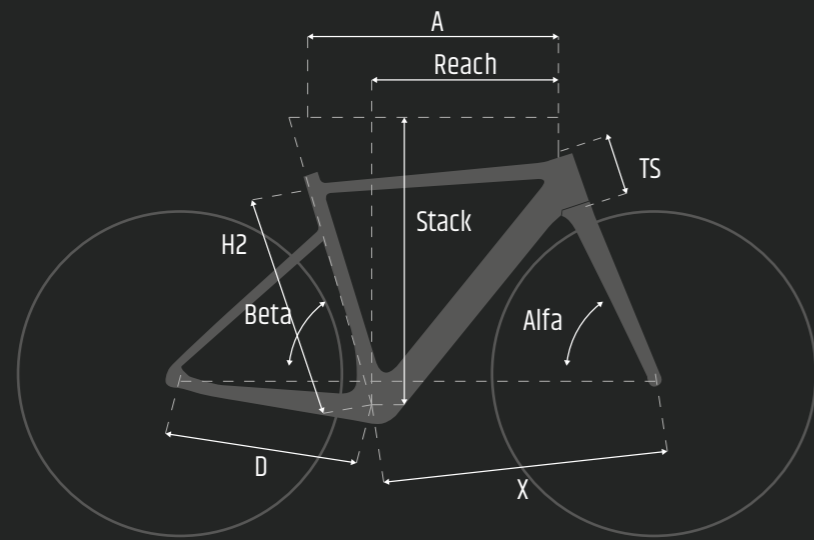

Measures	H2	A	X	D	TS	Beta	Alfa	Reach	Stack
SILVELLE FRAME INCLINED GEOMETRIES (mm)									
XS	440	510	574	425	90	75°	71,5°	373	511
S	490	525	580	425	95	74,5°	72°	382	517
M	520	535	585	425	105	74°	72°	384	527
L	540	540	591	425	125	74°	72°	384	546
XL	560	545	591	425	140	73,5°	72°	380	560

## Frame

**Fork** Carbon

**Headset** Oversize  
(1-1/2 - 1-1/2)

**BB Shell** Pressfit

**Seatpost** 27.2

**Thru axles** ✓

**Flat mount** ✓

## Components

**Pedals** Not included

**Saddle** San Marco Monza

**Seatpost** QTC Energy

**Stem** QTC Alloy

**Handlebar** QTC Energy

**Bottle cage** Not included

## Mounting options

**Groupset** Shimano GRX 600 1x11  
Shimano GRX 812 1x11  
SRAM Apex AXS 1x12

**Wheels** Ursus Orion Disc Alloy  
with Tires Challenge Grifo Wire 33

Ursus TS37 Carbon Tubular  
with Dugast tubulars



**GUERCIOTTI EXPORT Srl**

Via Petrocchi, 10  
20127 Milano - Italia

TEL +39 02 2826188  
FAX +39 02 26826954

**GUERCIOTTI.IT**